



MA3 Hydraulic Cylinders

'Mill Type' roundline cylinders for working pressures up to 250 bar



ENGINEERING YOUR SUCCESS.

CADE – Cylinder and Accumulator Division Europe

Made in Europe - serving all markets and industries



Parker CADE UK
Sandycroft, (Chester)

Parker CADE France
Colombes

Parker CADE Italy
Arsago & Turin

Parker CADE Sweden
Falköping







Parker CADE Poland
Wroclaw

Parker CADE Germany
Cologne

www.parker/clde



Our product range - click for more detail:

<https://discover.parker.com/FastTrackCADE>

Contents

	Page
<i>Introduction</i>	5
<i>Our Technology - Your Value</i>	6, 7
<i>Design Features and Benefits</i>	8, 9
<i>Mounting Styles</i>	
Overview	10
Round Flange Mountings	11 - 13
Foot Mountings	14, 15
Trunnion Mountings	16, 17
Pivot Mountings	18, 19
<i>Piston Rod End Data</i>	
Rod Bellows	20
Piston Rod Ends	20, 21
Accessories	22 - 25
<i>Cylinder Selection</i>	
Cylinder Mounting Information and Cylinder Masses	26
Selecting the Cylinder Diameter	27
Selecting the Piston Rod	28, 29
<i>Ports</i>	30 - 32
<i>Seals and Fluids</i>	33
<i>Cushioning</i>	34
<i>Replacement Parts and Service</i>	36, 37
<i>How to order</i>	38
<i>eConfigurator</i>	39



If you are using an electronic version of this catalogue this icon will take you back to this CONTENT page upon clicking.



If you are using an electronic version of this catalogue this icon will take you back to this HOW TO ORDER page upon clicking.



Parker – committed to your success

Parker Hannifin is the global leader in motion and control technologies. We employ more than 58,000 people in 48 countries, providing our customers with technical excellence and first class customer service. Parker is the world's largest supplier of hydraulic cylinders for industrial applications.

When you partner with Parker, you gain access to a vast range of resources designed to increase your productivity and profitability.

eConfigurator

Select the requested attributes to configure your customised cylinder.



Online Support

You can find the latest product information on the Parker website. Designed to be accessible via desktops, tablets and smart phones you can download software, brochures, manuals and 3D models. All of the latest product news and contact information is also included on the website.

www.parker.com/clde



WARNING – USER RESPONSIBILITY

FAILURE OR IMPROPER SELECTION OR IMPROPER USE OF THE PRODUCTS DESCRIBED HEREIN OR RELATED ITEMS CAN CAUSE DEATH, PERSONAL INJURY AND PROPERTY DAMAGE.

This document and other information from Parker-Hannifin Corporation, its subsidiaries and authorized distributors provide product or system options for further investigation by users having technical expertise.

The user, through its own analysis and testing, is solely responsible for making the final selection of the system and components and assuring that all performance, endurance, maintenance, safety and warning requirements of the application are met. The user must analyze all aspects of the application, follow applicable industry standards, and follow the information concerning the product in the current product catalog and in any other materials provided from Parker or its subsidiaries or authorized distributors.

To the extent that Parker or its subsidiaries or authorized distributors provide component or system options based upon data or specifications provided by the user, the user is responsible for determining that such data and specifications are suitable and sufficient for all applications and reasonably foreseeable uses of the components or systems.

Offer of Sale

Please contact your Parker representation for a detailed 'Offer of Sale'.

Introduction

The heavy duty series MA3 cylinder has been designed for service in steel mills and in other arduous applications where a rugged, dependable cylinder is required. In addition to the standard cylinders featured in this catalogue, MA3 cylinders can be designed and manufactured to suit individual customer requirements.

With over 100 years of experience, our team can provide industry leading solutions for your cylinder needs.

MA3 Series 'Mill' type hydraulic cylinders are premium quality, heavy duty cylinders which are fatigue-free at their full rated pressure of 250 bar. Designed for use in steel mills and similar demanding applications, MA3 Series cylinders incorporate service features such as removable glands and separate boies with detachable heads and caps to ensure ease of maintenance and low whole-life operating costs.

Like all cylinders from Parker Hydraulics, they are designed to deliver long, efficient service with low maintenance requirements, guaranteeing high productivity year after year. Parker's MA3 Series cylinders meet the requirements of ISO 6022 and DIN 2422.





Our Technology

- Heavy Duty construction
- Styles and dimensions conform to:
CETOP RP73H, ISO 6022, DIN 24 333,
AFNOR NF E48-025, VW 39D 921
- Rated pressure: 250 bar
- Fatigue-free at the rated pressure
- Hydraulic mineral oil – other fluids on request
- Temperature range of standard seals:
-20°C to +80°C
- Construction:
head and cap bolted to heavy steel flanges
- Bore sizes: 50mm to 320mm
- Piston rod diameters: 32mm to 220mm
- Cushioning – optional at both ends
- Air bleeds – optional at both ends
- Tested in accordance with ISO 10100 : 2001
- Primer coat: by default, hydraulic cylinders are primed with a coating color matt black RAL 9005, of min. 40 µm. Other colours upon request.



Your Value

- Heavy duty construction:
Absolute reliability even in high temperatures and under extreme conditions
- Customized heavy duty cylinder design, optimized for reliable long life
- Extensive variety of mounting options
- Premium Parker Service
- Compatible with fire resistant fluids
- Conforms to ISO 10100:2001
- REACH & RoHS compliant



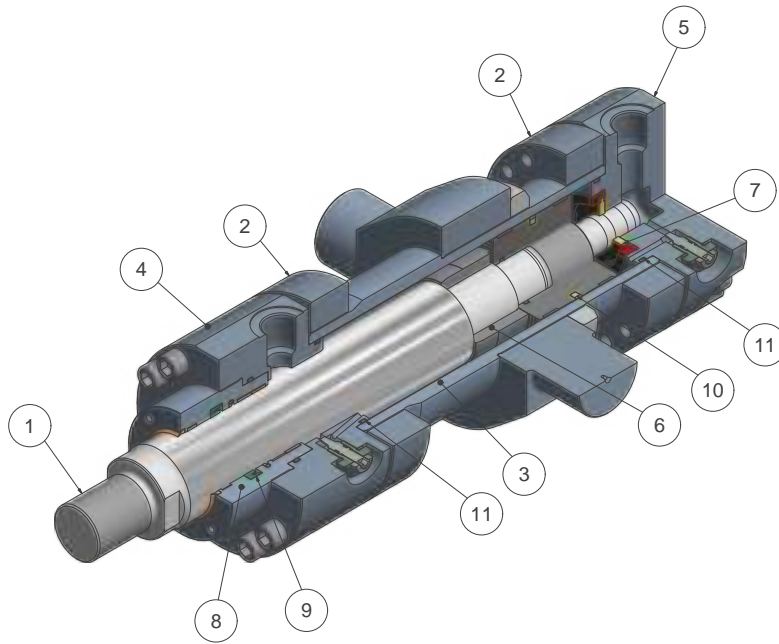

1 Piston Rod

The piston rod is manufactured from precision ground, high tensile carbon alloy steel, hard chrome plated and polished to 0.2µm max. Piston rods up to 140mm in diameter are induction case hardened to Rockwell C54 minimum before chrome plating. Thus providing a 'dent resistant' surface, resulting in improved seal life. Piston rods of 160mm diameter and above can be case hardened on request. All rod and piston assemblies are designed to be fatigue free at full rated pressure.

2 Head and Cap Retention

The head and cap are bolted to heavy steel flanges, which are retained by threads at each end of the cylinder body. The resulting assembly is fatigue-free at its maximum rated pressure.

3 Cylinder Body

The heavy wall steel tubing is honed to a high surface finish, to minimise internal friction and prolong seal life.

4 & 5 Head and Cap Ends

The head and cap are machined from steel and located into the cylinder body's internal diameter for added strength and precise alignment. To ensure leak-free performance, both the head and cap are sealed by 'O' rings which, in turn, are protected by anti-extrusion rings.

6 & 7 Cushioning

Optional cushions at the head and cap are progressive in action, providing controlled deceleration which reduces noise and shock loading, and prolongs machine life. The head end cushion is a self-centring sleeve, while the polished cap end spear is an integral part of the piston rod. Needle valves are provided at both ends of the cylinder for precise cushion adjustment, and are recessed and retained so that they cannot be inadvertently removed.

Check valves at the head and cap ends of the cylinder minimize restriction to the start of a stroke, permitting full power and fast cycle times. The head end check valve is incorporated into the fully floating cushion sleeve, while the cap end employs a floating bronze cushion bush.

8 Rod Gland and Bearings

Seals are housed in a corrosion-resistant steel gland, featuring heavy duty polymer bearing rings to resist side loadings. Wide separation of these rings reduces bearing stresses, maximising the service life of the bearing. On bore sizes up to 125mm the rod gland is threaded into the head as illustrated above while, on larger bore sizes, the rod gland is bolted to the head.

The polymer bearing rings, with the rod seals, are easily replaced on removal of the rod gland, and all components may be serviced without further disassembly of the cylinder.

9 & 10 Gland and Piston Seals

The gland seals provide efficient retention of pressurized fluid while preventing the ingress of contaminants. A variety of gland and piston seal options is available, to suit different applications. MA3 cylinders can also be designed and manufactured with seals to suit individual customer requirements. Please contact the factory with details of the application.

11 Body End Seals

To ensure leak-free performance, body end seals and gland/head seals are of radial construction, avoiding the problems of 'nibbling' and early failure associated with face-type seals.

Gland and Piston Seal Options

See Illustrations, **page 33**

Standard Option

The standard seals fitted to MA3 cylinders provide excellent low speed and break-out performance and deliver exceptional working life in high cycle applications. They are suitable for use with Group 1 fluids (see page 31) and may be used for piston speeds up to 0.5m/s.

Standard gland seals employ a polyurethane lipseal and a PTFE stepped seal. The piston is fitted with a heavy duty filled polymer seal and heavy duty wear rings. The wear rings prevent contact between the piston and cylinder bore and protect the piston seal from contaminants.

Low Friction Option

Low friction seals are suitable for applications where very low friction and an absence of stick-slip are important. They are not suitable for holding loads in a fixed position. Low friction seals are available for use with all fluid groups and are suitable for piston speeds up to 1m/s.

Low Friction gland seals comprise two low friction PTFE stepped seals and a heavy duty wiperseal, while the pistons employ a PTFE seal and PTFE wear rings.

Chevron Option

The combination of chevron gland and chevron piston seals is designed to withstand harsh environments such as steel mills. They are suitable for use with all fluid groups and for piston speeds up to 0.5m/s, and may be used to hold a load in position.

Chevron gland seals have a corrosion-resistant steel retainer, and a separate removable steel housing which retains the inner bearing rings. A heavy duty wiper seal prevents the ingress of contaminants. Chevron pistons feature a two-piece piston with a wide bearing ring mounted between chevron seals.

Load Holding Option

Suitable for applications where loads are required to be held in position, the Load Holding option combines the low friction performance and long life of the standard gland seals with the rugged qualities of the chevron piston seal. The load holding option may be used for piston speeds up to 0.5m/s and is suitable for use with Group 1 fluids.

Air Bleeds

Available as an option at both ends, air bleeds are recessed into the head and cap and retained so they cannot be inadvertently removed. The air bleed location, in relation to the supply port location, must be specified on the order – see page 30.

Test Points

Available as an option at both ends the test points location must be specified on the order. See page 20.

Gland Drains

The tendency of hydraulic fluid to adhere to the piston rod can result in an accumulation of fluid in the cavity between the seals under certain operating conditions. This may occur with long stroke cylinders, where there is a constant back pressure as in differential circuitry, or where the ratio of the extend speed to the retract speed is greater than 2 to 1.

Gland drains should be piped back to the fluid reservoir, which should be located below the level of the cylinder.

Position Switches and Feedback Devices

Non-contacting position switches and linear position transducers of various types may be fitted to MA3 series cylinders. Please contact the factory for further details.

Rod End Bellows

Exposed rod surfaces that are subjected to air hardening contaminants should be protected by rod end bellows. Longer rod extensions are required to accommodate their collapsed length – see page 18.

Rod Material

As an alternative to the normal piston rod material, stainless steel and other special materials and finishes can be supplied.

Metallic Rod Wipers

For applications where contaminants may adhere to the extended piston rod and thereby cause premature failure of gland seals, the use of a metallic rod wiper in place of the standard wiper seal is recommended.

Special Designs

Alternative sealing arrangements, special mounting styles, higher or lower rated pressure designs, welded cap ends to reduce overall length (non-cushioned only), larger bores and alternative rod sizes are just a few of the special requirements which can be accommodated by our design and engineering staff.

Marine Environments

MA3 cylinders can be supplied with modifications to material and paint specifications which make them suitable for operation in a marine environment. Please consult the factory.

Servicing Features

The MA3 series has been designed to make maintenance as easy as possible, by incorporating the following design features:

- **Removable Gland** – Rod bearing and rod seals can be replaced without completely dismantling the cylinder. For chevron glands, a thread is machined on the outside diameter of the seal housing to assist extraction.
- **Chamfers** at both ends of the cylinder body ease assembly of the head and cap and insertion of the piston seals.
- **Retaining flanges** are removable, allowing separate replacement of the cylinder body. Flanges are spaced from the head and cap to allow the bolts to be sawn through in the event of severe damage or corrosion.
- **High tensile bolts** are used for ease of maintenance.

Mounting Styles

Cylinder mountings transmit the force applied by the cylinder to the surface on which it is mounted. They are responsible for controlling alignment and resisting movement which would result in fatigue failure. The most efficient transmission of force occurs along the cylinder's centre line as with flange-mounted cylinders. Trunnion mounted cylinders also absorb force on their centreline, but lack the rigidity of a fixed mounting. Foot-mounted cylinders do not absorb force on their centrelines and should be firmly secured, using a thrust key for positive location where necessary. Different mounting options give freedom to the designer when building a hydraulic cylinder into a machine. A correctly specified mounting ensures a long service life with low maintenance demands. The MA3 cylinder series offers a wide range of mounting styles. See below for the available options.

ROUND FLANGE MOUNTINGS



Style MF4
Cap Circular Flange, p. 11



Style MF3
Head Circular Flange, p.12



Style MF3
Double Rod, p.13

FOOT MOUNTINGS



Style MS2
Foot Mounting
(Not to ISO 6022), p.14



Style MS2
Foot Mounting
Double Rod
(Not to ISO 6022), p.15

TRUNNION MOUNTINGS



Style MT4
Intermediate Trunnion, p.16



Style MT4
Intermediate Trunnion
Double Rod, p.17

PIVOT MOUNTINGS



Style MP5
Cap Fixed Eye
with Spherical Bearing, p.18



Style MP3
Cap Fixed Eye, p.19



Style MF4
Cap Circular Flange

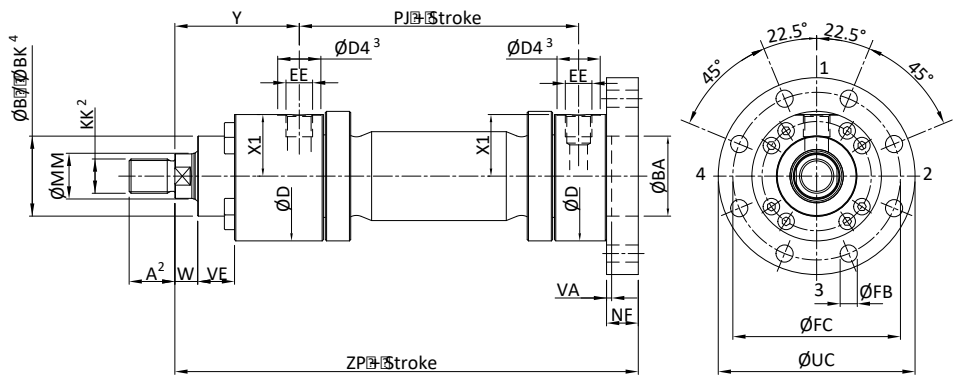

Dimensions – MF4

Bore \varnothing	Rod No.	MM Rod \varnothing	$\varnothing B$	$\varnothing BA$ H8	$\varnothing D$ max.	X1	EE (BSP)	$\varnothing D4$	$\varnothing FB$ H13 8x	$\varnothing FC$ jS13	NF jS13	$\varnothing UC$ max.	VA min.	VE	W	Min. Stroke	Y	+ Stroke	
																		PJ	ZP
50	1 2	32 36	63	63	102	48.5	G $\frac{1}{2}$	34	13.5	132	25	155	4	29	18	0	98	120	265
63	1 2	40 45	75	75	120	56.5	G $\frac{3}{4}$	42	13.5	150	28	175	4	32	21	0	112	133	298
80	1 2	50 56	90	90	145	69.5	G $\frac{3}{4}$	42	17.5	180	32	210	5	36	24	0	120	155	332
100	1 2	63 70	110	110	170	82	G1	47	22	212	36	250	5	41	27	0	134	171	371
125	1 2	80 90	132	132	206	100.5	G1	47	22	250	40	290	6	45	31	0	153	205	430
140	1 2	90 100	145	145	226	109.5	G $\frac{1}{4}$	58	26	285	40	330	5	45	31	0	166	219	465
160	1 2	100 110	160	160	265	129.5	G $\frac{1}{4}$	58	26	315	45	360	7	50	35	0	185	235	505
180	1 2	110 125	185	185	292	143.5	G $\frac{1}{4}$	58	33	355	50	410	5	55	40	0	194	264	550
200	1 2	125 140	200	200	306	150.5	G $\frac{1}{4}$	58	33	385	56	440	10	61	40	0	220	278	596
220 ¹	1 2	140 160	235	235	355	174	G $\frac{1}{2}$	65	39	435	63	500	10	71	42	0	244	326	690
250	1 2	160 180	250	250	395	194	G $\frac{1}{2}$	65	39	475	63	540	10	71	42	0	257	326	703
320	1 2	200 220	320	320	490	243	G $\frac{1}{2}$	65	45	600	80	675	10	88	48	0	282	391	830

¹ Piston \varnothing not according with ISO 6022

² See Rod End dimensions on page 21

³ $\varnothing D4$ max 0,5mm deep

⁴ See details on page 21



Style MF3
 Head Circular Flange

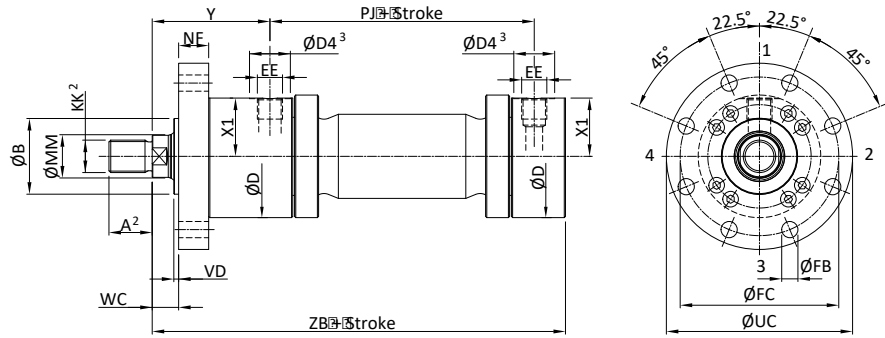

Dimensions – MF3

Bore ϕ	Rod No.	MM Rod ϕ	ϕB f8	ϕD max.	X1	EE (BSP)	$\phi D4$	ϕFB H13 8x	ϕFC jS13	NF jS13	ϕUC max.	VD min	WC	Min. Stroke	Y	+ Stroke	
																PJ	ZB max.
50	1 2	32 36	63	102	48.5	G $1/2$	34	13.5	132	25	155	4	22	0	98	120	244
63	1 2	40 45	75	120	56.5	G $3/4$	42	13.5	150	28	175	4	25	0	112	133	274
80	1 2	50 56	90	145	69.5	G $3/4$	42	17.5	180	32	210	4	28	0	120	155	305
100	1 2	63 70	110	170	82	G1	47	22	212	36	250	5	32	0	134	171	340
125	1 2	80 90	132	206	100.5	G1	47	22	250	40	290	5	36	0	153	205	396
140	1 2	90 100	145	226	109.5	G1 $1/4$	58	26	285	40	330	5	36	0	166	219	430
160	1 2	100 110	160	265	129.5	G1 $1/4$	58	26	315	45	360	5	40	0	185	235	467
180	1 2	110 125	185	292	143.5	G1 $1/4$	58	33	355	50	410	5	45	0	194	264	505
200	1 2	125 140	200	306	150.5	G1 $1/4$	58	33	385	56	440	5	45	0	220	278	550
220 ¹	1 2	140 160	235	355	174	G1 $1/2$	65	39	435	63	500	8	50	0	244	326	637
250	1 2	160 180	250	395	194	G1 $1/2$	65	39	475	63	540	8	50	0	257	326	650
320	1 2	200 220	320	490	243	G1 $1/2$	65	45	600	80	675	8	56	0	282	391	760

¹ Piston ϕ not according with ISO 6022

² See Rod End dimensions on page 21

³ $\phi D4$ max 0,5mm deep



Style MF3
Double Rod

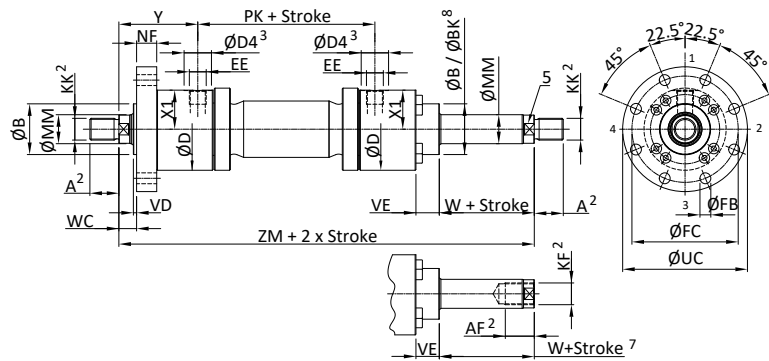

Dimensions – MF3

Bore Ø	Rod No.	MM Rod Ø	Ø B f8	Ø D max.	X1	EE (BSPP)	Ø D4	Ø FB H13 8x	Ø FC jS13	NF jS13	Ø UC max.	VD min	WC	VE	W	Ø BK	Y	Min. Stroke	Min. Stroke ⁷ +stroke	PK	ZM +2x stroke
50	1 2	32 36	63	102	48.5	G1/2	34	13.5	132	25	155	4	22	29	18	-	98	0	10	120	316
63	1 2	40 45	75	120	56.5	G3/4	42	13.5	150	28	175	4	25	32	21	-	112	0	10	133	357
80	1 2	50 56	90	145	69.5	G3/4	42	17.5	180	32	210	4	28	36	24	-	120	0	10	155	395
100	1 2	63 70	110	170	82	G1	47	22	212	36	250	5	32	41	27	-	134	0	20	171	439
125	1 2	80 90	132	206	100.5	G1	47	22	250	40	290	5	36	45	31	-	153	0	20	205	511
140	1 2	90 100	145	226	109.5	G1 1/4	58	26	285	40	330	5	36	45	31	169	166	0	30	219	551
160	1 2	100 110	160	265	129.5	G1 1/4	58	26	315	45	360	5	40	50	35	192	185	0	30	235	605
180	1 2	110 125	185	292	143.5	G1 1/4	58	33	355	50	410	5	45	55	40	218	194	0	40	264	652
200	1 2	125 140	200	306	150.5	G1 1/4	58	33	385	56	440	5	45	61	40	235	220	0	30	278	718
220 ¹	1 2	140 160	235	355	174	G1 1/2	65	39	435	63	500	8	50	71	42	272	244	0	50	326	814
250	1 2	160 180	250	395	194	G1 1/2	65	39	475	63	540	8	50	71	42	297	257	0	60	326	840
320	1 2	200 220	320	490	243	G1 1/2	65	45	600	80	675	8	56	88	48	363	282	0	90	391	955

¹ Piston Ø not according with ISO 6022

² See Rod End dimensions on page 21

³ ØD4 max 0,5mm deep

⁴ Double rod cylinders are denoted by a "k" in the cylinder model code shown on page 38

⁵ Rod Strength: double rod cylinders employ two separate piston rods, with one screwed into the end of the other within the piston assembly. As a result, one piston rod is stronger than the other. The stronger rod can be identified by the letter "K" stamped on its end.

⁶ Double-acting cylinder not standardized

⁷ Min. stroke if secondary piston rod style is "9"

⁸ See details on page 21



Style MS2
Foot Mounting
(Not to ISO 6022)

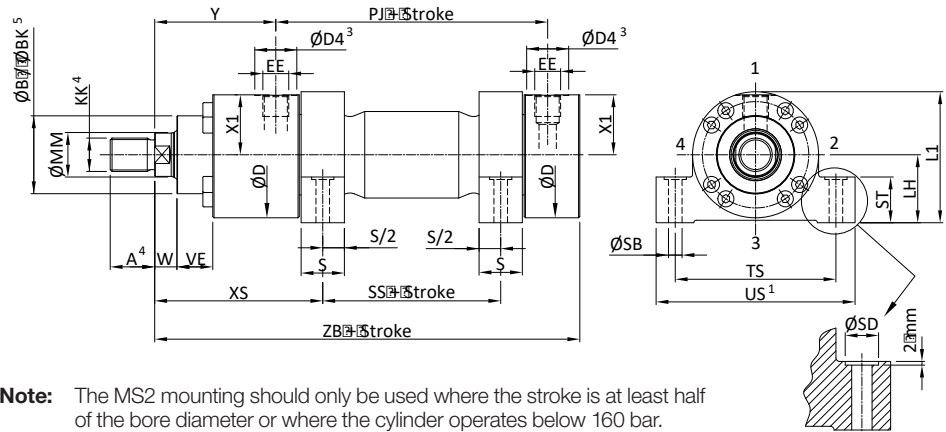

Note: The MS2 mounting should only be used where the stroke is at least half of the bore diameter or where the cylinder operates below 160 bar.

Dimensions – MS2

Bore Ø	Rod No.	MM Rod Ø	Ø B	D max	X1	EE (BSPP)	Ø D4	L1 max.	LH h10	SB H13	S	ØSD	ST	TS jS13	US	VE	W	XS	Y	Min. Stroke	+ Stroke		
																					PJ	SS	ZB max
50	1/2	32/36	63	102	48.5	G1/2	34	110	55	11	35	18	37	130	161	29	18	135.5	98	25	120	45	244
63	1/2	40/45	75	120	56.5	G3/4	42	129	65	13.5	40	20	42	150	183	32	21	154	112	25	133	49	274
80	1/2	50/56	90	145	69.5	G3/4	42	149	75	17.5	50	26	47	180	220	36	24	171.5	120	35	155	52	305
100	1/2	63/70	110	170	82	G1	47	181	90	22	60	33	57	210	260	41	27	189	134	35	171	61	340
125	1/2	80/90	132	206	100.5	G1	47	215	105	26	70	40	67	255	313	45	31	218	153	25	205	75	396
140	1/2	90/100	145	226	109.5	G1/4	58	235	115	30	85	48	72	290	359	45	31	240.5	166	45	219	70	430
160	1/2	100/110	160	265	129.5	G1/4	58	277	135	33	105	48	77	330	402	50	35	270	185	70	235	65	467
180	1/2	110/125	185	292	143.5	G1/4	58	305	150	40	115	60	92	360	445	55	40	291.5	194	75	264	69	505
200	1/2	125/140	200	306	150.5	G1/4	58	322	160	40	125	60	97	385	471	61	40	322.5	220	80	278	73	550
220 ²	1/2	140/160	235	355	174	G1/2	65	370	185	45	155	70	102	445	541	71	42	369.5	244	125	326	75	637
250	1/2	160/180	250	395	194	G1/2	65	408	205	52	155	76	112	500	610	71	42	382.5	257	120	326	75	650
320	1/2	200/220	320	490	243	G1/2	65	505	255	62	190	110	142	610	732	88	48	435	282	205	391	85	760

¹ The specified dimensions are maximum values, tolerance classes 342 according to ISO 9013 Thermal cutting

² Piston Ø not according with ISO 6022

³ ØD4 max 0,5mm deep

⁴ See Rod End dimensions on page 21

⁵ See details on page 21



Style MS2
Foot Mounting
Double Rod
(Not to ISO 6022)

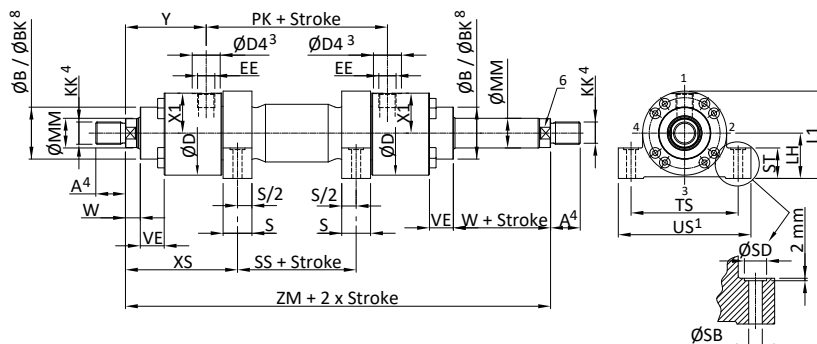

Note: The MS2 mounting should only be used where the stroke is at least half of the bore diameter or where the cylinder operates below 160 bar.

Dimensions – MS2

Bore Ø	Rod No.	MM Rod Ø	Ø B	D max	X1	EE (BSPP)	Ø D4	L1 max.	LH h10	SB H13	S	Ø SD	ST	TS jS13	US	VE	W	Ø BK	XS	Y	Min. Stroke	+ Stroke PK	SS	ZM +2x stroke
50	1 2	32 36	63	102	48.5	G1/2	34	110	55	11	35	18	37	130	161	29	18	-	135.5	98	25	120	45	316
63	1 2	40 45	75	120	56.5	G3/4	42	129	65	13.5	40	20	42	150	183	32	21	-	154	112	25	133	49	357
80	1 2	50 56	90	145	69.5	G3/4	42	149	75	17.5	50	26	47	180	220	36	24	-	171.5	120	35	155	52	395
100	1 2	63 70	110	170	82	G1	47	181	90	22	60	33	57	210	260	41	27	-	189	134	35	171	61	439
125	1 2	80 90	132	206	100.5	G1	47	215	105	26	70	40	67	255	313	45	31	-	218	153	25	205	75	511
140	1 2	90 100	145	226	109.5	G1 1/4	58	235	115	30	85	48	72	290	359	45	31	169	240.5	166	45	219	70	551
160	1 2	100 110	160	265	129.5	G1 1/4	58	277	135	33	105	48	77	330	402	50	35	192	270	185	70	235	65	605
180	1 2	110 125	185	292	143.5	G1 1/4	58	305	150	40	115	60	92	360	445	55	40	218	291.5	194	75	264	69	652
200	1 2	125 140	200	306	150.5	G1 1/4	58	322	160	40	125	60	97	385	471	61	40	235	322.5	220	80	278	73	718
220 ²	1 2	140 160	235	355	174	G1 1/2	65	370	185	45	155	70	102	445	541	71	42	272	369.5	244	125	326	75	814
250	1 2	160 180	250	395	194	G1 1/2	65	408	205	52	155	76	112	500	610	71	42	297	382.5	257	120	326	75	840
320	1 2	200 220	320	490	243	G1 1/2	65	505	255	62	190	110	142	610	732	88	48	363	435	282	205	391	85	955

¹ The specified dimensions are maximum values, tolerance classes 342 according to ISO 9013 Thermal cutting

² Piston Ø not according with ISO 6022

³ ØD4 max 0,5mm deep

⁴ See Rod End dimensions on page 21

⁵ Double rod cylinders are denoted by a "k" in the cylinder model code shown on page 38

⁶ Rod Strength: double rod cylinders employ two separate piston rods, with one screwed into the end of the other within the piston assembly. As a result, one piston rod is stronger than the other. The stronger rod can be identified by the letter "K" stamped on its end.

⁷ Double-acting cylinder not standardized

⁸ See details on page 21



Style MT4
Intermediate Trunnion

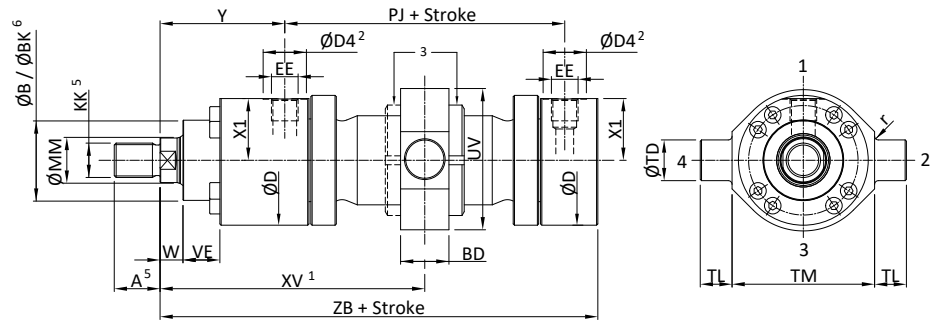

Dimensions – MT4 See also Trunnion Blocks, p. 23

Bore \varnothing	Rod No.	MM Rod \varnothing	B	BD	D max	X1	EE (BSPP)	$\varnothing D4$	TD f8	r min	TL js13	TM h12	UV max	W	VE	XV min	Min. Stroke	Y	+ Stroke		
																			PJ	XV max	ZB max
50	1 2	32 36	63	38	102	48.5	G $1/2$	34	32	3	25	112	111	18	29	174	34	98	120	140	244
63	1 2	40 45	75	48	120	56.5	G $3/4$	42	40	3	32	125	129	21	32	202	47	112	133	155	274
80	1 2	50 56	90	58	145	69.5	G $3/4$	42	50	3	40	150	163	24	36	232	69	120	155	163	305
100	1 2	63 70	110	78	170	82	G1	47	63	3	50	180	188	27	41	268	97	134	171	171	340
125	1 2	80 90	132	98	206	100.5	G1	47	80	3	63	224	234	31	45	316	121	153	205	195	396
140	1 2	90 100	145	118	226	109.5	G $1/4$	58	90	3	70	265	257	31	45	343	135	166	219	208	430
160	1 2	100 110	160	128	265	129.5	G $1/4$	58	100	3	80	280	287	35	50	377	149	185	235	228	467
180	1 2	110 125	185	138	292	143.5	G $1/4$	58	110	3	90	320	328	40	55	405	158	194	264	247	505
200	1 2	125 140	200	178	306	150.5	G $1/4$	58	125	3	100	335	343	40	61	461	204	220	278	257	550
220 ⁴	1 2	140 160	235	180	355	174	G $1/2$	65	160	3	125	385	393	42	71	508	202	244	326	306	637
250	1 2	160 180	250	180	395	194	G $1/2$	65	160	3	125	425	433	42	71	525	210	257	326	315	650
320	1 2	200 220	320	220	490	243	G $1/2$	65	200	3	160	530	536	48	88	640	325	282	391	315	760

¹ XV Dimension to be specified by customer. Where minimum dimension is unacceptable, please consult factory

² $\varnothing D4$ max 0,5mm deep

³ NUT Position depends on stroke length and XV. Trunnion nut up to $\varnothing 200$ bore

⁴ Piston \varnothing not according with ISO 6022

⁵ See Rod End dimensions on page 21

⁶ See details on page 21



Style MT4
 Intermediate Trunnion
 Double Rod

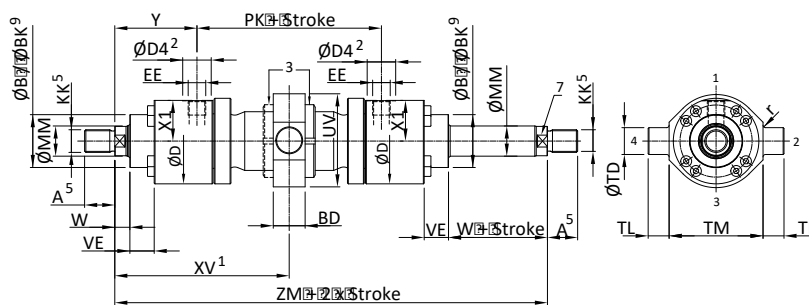

Dimensions – MT4 See also Trunnion Blocks, p. 23

Bore Ø	Rod No.	MM Rod Ø	B	BD	D max	X1	EE (BSP)	Ø D4	TD f8	r	TL js13	TM h12	UV max	W	VE	BK Ø	XV min	Min. Stroke	Y	+ Stroke		ZM +2x stroke
																				PK	XV max	
50	1 2	32 36	63	38	102	48.5	G ¹ / ₂	34	32	3	25	112	111	18	29	–	174	34	98	120	140	316
63	1 2	40 45	75	48	120	56.5	G ³ / ₄	42	40	3	32	125	129	21	32	–	202	47	112	133	155	357
80	1 2	50 56	90	58	145	69.5	G ³ / ₄	42	50	3	40	150	163	24	36	–	232	69	120	155	163	395
100	1 2	63 70	110	78	170	82	G1	47	63	3	50	180	188	27	41	–	268	97	134	171	171	439
125	1 2	80 90	132	98	206	100.5	G1	47	80	3	63	224	234	31	45	–	316	121	153	205	195	511
140	1 2	90 100	145	118	226	109.5	G ¹ / ₄	58	90	3	70	265	257	31	45	169	343	135	166	219	208	551
160	1 2	100 110	160	128	265	129.5	G ¹ / ₄	58	100	3	80	280	287	35	50	192	377	149	185	235	228	605
180	1 2	110 125	185	138	292	143.5	G ¹ / ₄	58	110	3	90	320	328	40	55	218	405	158	194	264	247	652
200	1 2	125 140	200	178	306	150.5	G ¹ / ₄	58	125	3	100	335	343	40	61	235	461	204	220	278	257	718
220 ⁴	1 2	140 160	235	180	355	174	G ¹ / ₂	65	160	3	125	385	393	42	71	272	508	202	224	326	306	814
250	1 2	160 180	250	180	395	194	G ¹ / ₂	65	160	3	125	425	433	42	71	297	525	210	257	326	315	840
320	1 2	200 220	320	220	490	243	G ¹ / ₂	65	200	3	160	530	536	48	88	363	640	325	282	391	315	955

¹ XV Dimension to be specified by customer. Where minimum dimension is unacceptable, please consult factory
² ØD4 max 0,5mm deep
³ NUT Position depends on stroke length and XV. Trunnion nut up to Ø200 bore
⁴ Piston Ø not according with ISO 6022
⁵ See Rod End dimensions on page 21
⁶ Double rod cylinders are denoted by a "k" in the cylinder model code shown on page 38
⁷ Rod Strength: double rod cylinders employ two separate piston rods, with one screwed into the end of the other within the piston assembly. As a result, one piston rod is stronger than the other. The stronger rod can be identified by the letter "K" stamped on its end.
⁸ Double-acting cylinder not standardized
⁹ See details on page 21

Pivot Mountings

'Mill Type' Cylinders
MA3 Series



Style MP5
Cap Fixed Eye
with Spherical Bearing

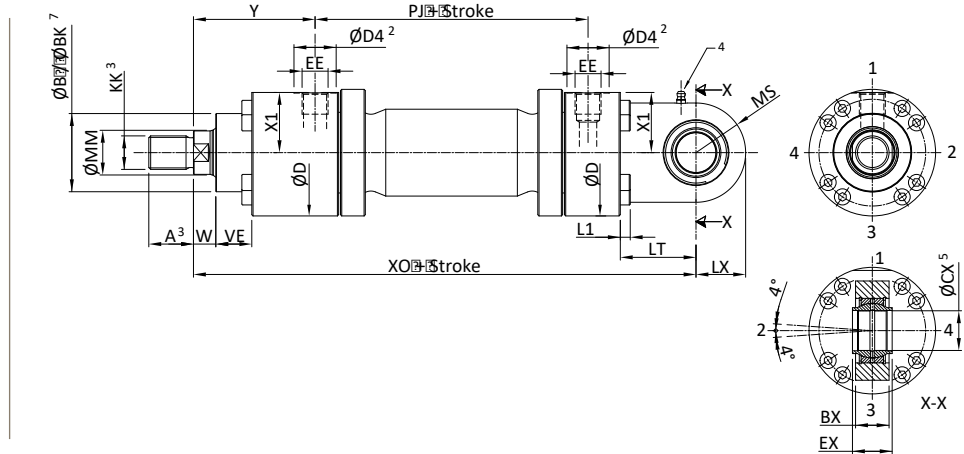

Dimensions – MP5

Bore \varnothing	Rod No.	MM Rod \varnothing	$\varnothing B$	BX	EX h12	CX H7	D max	X1	EE (BSPP)	$\varnothing D4$	L1	LT	LX	MS	W	VE	Y	Min. Stroke	+ Stroke	
																			PJ	XO
50	1 2	32 36	63	27	32	32	102	48.5	G1/2	34	8	61	40	40	18	29	98	0	120	305
63	1 2	40 45	75	35	40	40	120	56.5	G3/4	42	10	74	50	50	21	32	112	0	133	348
80	1 2	50 56	90	40	50	50	145	69.5	G3/4	42	12	90	61.5	61.5	24	36	120	0	155	395
100	1 2	63 70	110	52	63	63	170	82	G1	47	14	102	71	66	27	41	134	0	171	442
125	1 2	80 90	132	60	80	80	206	100.5	G1	47	16	124	90	90	31	45	153	0	205	520
140	1 2	90 100	145	65	90	90	226	109.5	G1 1/4	58	16	150	100	100	31	45	166	0	219	580
160	1 2	100 110	160	84	100	100	265	129.5	G1 1/4	58	20	150	112	112	35	50	185	0	235	617
180	1 2	110 125	185	88	110	110	292	143.5	G1 1/4	58	20	185	129	129	40	55	194	0	264	690
200	1 2	125 140	200	102	125	125	306	150.5	G1 1/4	58	20	206	145	145	40	61	220	0	278	756
220 ¹	1 2	140 160	235	130	160	160	355	174	G1 1/2	65	22	253	187 ⁶	179 ⁶	42	71	244	0	326	890
250	1 2	160 180	250	130	160	160	395	194	G1 1/2	65	24	253	187 ⁶	179 ⁶	42	71	257	0	326	903
320	1 2	200 220	320	162	200	200	490	243	G1 1/2	65	33	320	241 ⁶	231 ⁶	48	88	282	0	391	1080

¹ Piston \varnothing not according with ISO 6022

² $\varnothing D4$ max 0,5mm deep

³ See Rod End dimensions on page 21

⁴ Grease nipple DIN71412 form A

⁵ Related bolt $\varnothing f8$

⁶ The specified dimensions are maximum values, tolerance classes 342 according to ISO9013 thermal cutting

⁷ See details on page 21



Style MP3
Cap Fixed Eye

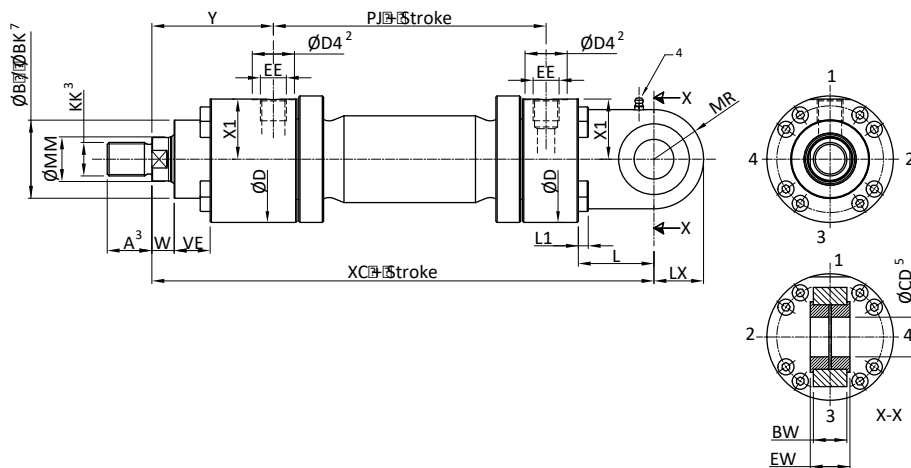

Dimensions – MP3

Bore \varnothing	Rod No.	MM Rod \varnothing	$\varnothing B$	BW	EW h12	CD H9	D max	X1	EE (BSPP)	$\varnothing D4$	L1	L	LX	MR	W	VE	Y	Min. Stroke	+ Stroke	
																			PJ	XC
50	1 2	32 36	63	27	32	32	102	48.5	G1/2	34	8	61	40	40	18	29	98	0	120	305
63	1 2	40 45	75	35	40	40	120	56.5	G3/4	42	10	74	50	50	21	32	112	0	133	348
80	1 2	50 56	90	40	50	50	145	69.5	G3/4	42	12	90	61.5	61.5	24	36	120	0	155	395
100	1 2	63 70	110	52	63	63	170	82	G1	47	14	102	71	66	27	41	134	0	171	442
125	1 2	80 90	132	60	80	80	206	100.5	G1	47	16	124	90	90	31	45	153	0	205	520
140	1 2	90 100	145	65	90	90	226	109.5	G1 1/4	58	16	150	100	100	31	45	166	0	219	580
160	1 2	100 110	160	84	100	100	265	129.5	G1 1/4	58	20	150	112	112	35	50	185	0	235	617
180	1 2	110 125	185	88	110	110	292	143.5	G1 1/4	58	20	185	129	129	40	55	194	0	264	690
200	1 2	125 140	200	102	125	125	306	150.5	G1 1/4	58	20	206	145	145	40	61	220	0	278	756
220 ¹	1 2	140 160	235	130	160	160	355	174	G1 1/2	65	22	253	187 ⁶	179 ⁶	42	71	244	0	326	890
250	1 2	160 180	250	130	160	160	395	194	G1 1/2	65	24	253	187 ⁶	179 ⁶	42	71	257	0	326	903
320	1 2	200 220	320	162	200	200	490	243	G1 1/2	65	33	320	241 ⁶	231 ⁶	48	88	282	0	391	1080

¹ Piston \varnothing not according with ISO 6022

² $\varnothing D4$ max 0,5mm deep

³ See Rod End dimensions on page 21

⁴ Grease nipple DIN71412 form A

⁵ Related bolt $\varnothing 8$

⁶ The specified dimensions are maximum values, tolerance classes 342 according to ISO9013 thermal cutting

⁷ See details on page 21

Rod Bellows

Bore Ø	Rod Ø	Rod bellows Øe ¹	W quote without rod bellows
50	32 36	100	18
63	40 45	118	21
80	50 56	143	24
100	63 70	165	27
125	80 90	180	31
140	90 100	200	31
160	100 110	210	35
180	110 125	240	40
200	125 140	260	40
220	140 160	310	42
250	160 180	330	42
320	200 220	380	48

¹ Recommended

² W quote with rod bellows

³ Available materials: further materials contact Parker Cylinder Division

TEST POINTS

Test points with threaded connection M16x2

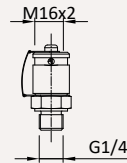

Available also other threads.
 For omitted dimensions see technical handbook/catalogue 4100/UK.

Calculation for new W with Rod Bellows

$$(0.11 \times \text{Stroke}) + 25$$

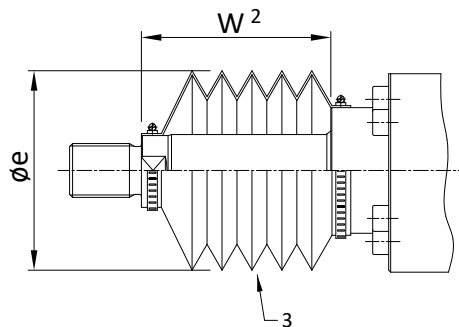

Piston Rod End

Piston Rod End Styles

MA3 cylinders are available with standard metric male and female rod ends to ISO 4395. They can also be supplied with other rod end threads, eg: ISO metric coarse, Unified, British Standard etc., or the customer's special requirements.

Rod End Codes 4 and 9

Each cylinder bore size is offered with two diameters of piston rod - the smaller is designated no. 1 and the larger, no. 2. The standard male rod end threads, to ISO 6022, are designated code 4 and female threads are designated code 9. Female threads are only available with the no. 2 rod size.

Rod End Code 3

Non-standard rod ends are designated code 3. Orders for these should include dimensioned sketches and descriptions, showing dimensions KK or KF, A or AF, rod stand-out W and the thread form required.

Wrench Flats

Piston rods up to and including 90mm in diameter are supplied with flats for a spanner wrench while rods above 90mm in diameter feature four drilled holes to accept a pin wrench. See dimension D in the table on page 21.

Rod End Code 4

Bore Ø 50mm - 125mm

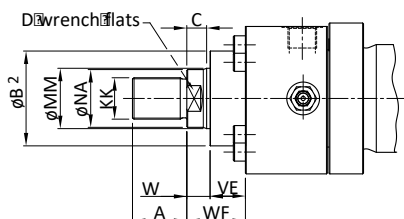

Rod End Code 4

Bore Ø 140mm - 320mm

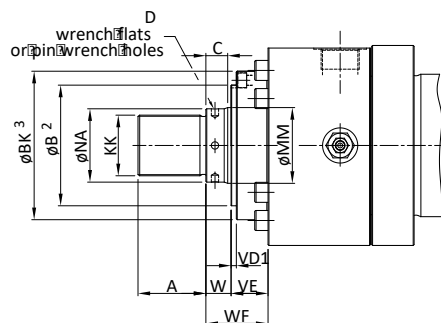

Rod End Code 9

Bore Ø 50mm - 125mm

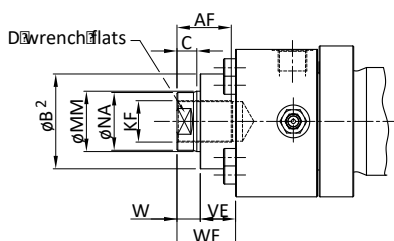

Rod End Code 9

Bore Ø 140mm - 320mm

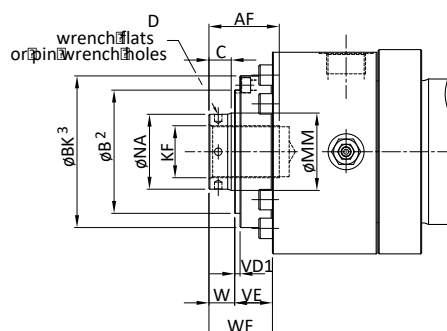

Rod End Dimensions See also Cylinder Dimensions, pp 9 - 17, Codes 1, 2

Bore Ø	Rod No.	MM Rod Ø	A & AF	C	D	KK Code 4	KF Code 9	NA	W	VE	WF	B	BK	VD1
50	1 2	32 36	36	15	28 32	M27x2	- M27x2	31 35	18	29	47	63	-	-
63	1 2	40 45	45	18	34 36	M33x2	- M33x2	38 43	21	32	53	75	-	-
80	1 2	50 56	56	20	43 46	M42x2	- M42x2	48 54	24	36	60	90	-	-
100	1 2	63 70	63	23	53 60	M48x2	- M48x2	60 67	27	41	68	110	-	-
125	1 2	80 90	85	27	65 75	M64x3	- M64x3	77 87	31	45	76	132	-	-
140	1 2	90 100	90	27	75 Ø10 x 4	M72x3	- M72x3	87 96	31	45	76	145	169	5,5
160	1 2	100 110	95	31	Ø10 x 4 Ø10 x 4	M80x3	- M80x3	96 106	35	50	85	160	192	5,5
180	1 2	110 125	105	36	Ø10 x 4 Ø10 x 4	M90x3	- M90x3	106 121	40	55	95	185	218	5,5
200	1 2	125 140	112	36	Ø12 x 4 Ø12 x 4	M100x3	- M100x3	121 136	40	61	101	200	235	5,5
220 ¹	1 2	140 160	125	38	Ø12 x 4 Ø15 x 4	M125x4	- M125x4	136 155	42	71	113	235	272	8,5
250	1 2	160 180	125	38	Ø15 x 4 Ø15 x 4	M125x4	- M125x4	155 175	42	71	113	250	297	8,5
320	1 2	200 220	160	44	Ø15 x 4 Ø15 x 4	M160x4	- M160x4	194 214	48	88	136	320	363	8,5

¹ Piston Ø not according with ISO 6022

² Like dimensions on pages 11 - 19

³ Like dimensions on pages 13, 15, 17

Accessory Selection

The accessories and corresponding mounting brackets supplied for use at the piston rod end of a cylinder are selected by reference to the rod end thread, shown on page 19, while the same mounting brackets, when used at the cap end of pivot mounted cylinders, are selected by pin size – see dimensions CD and CX on pages 18, 19.

Rod End

Rod clevis and pivot pin	p. 22
Rod eye with plain bearing	p. 23
Clevis bracket and pivot pin	p. 23
Rod eye with spherical bearing	p. 24
Mounting bracket and pivot pin	p. 24

Cap End

Clevis bracket and pivot pin – for style MP3 and MP5 mountings	p. 23
Mounting bracket and pivot pin – for style MP3 and MP5 mountings	p. 24

Cylinder Body

Trunnion blocks for style MT4 mounting	p. 25
--	-------

Rod Clevis and Pivot Pin AP2 ISO 8132

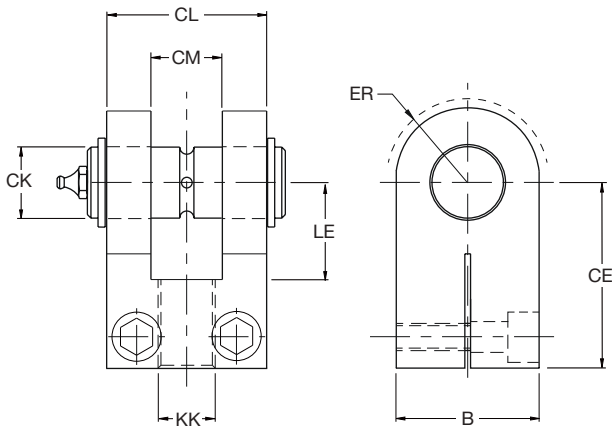

Part No.	B	CE js13	CK H9/f8	CL h16	CM A13	ER max	KK	LE min	Mass kg	Nominal Force kN
0962130032	65	80	32	70	32	40	M27x2	41	2.2	50
0962130040	80	97	40	90	40	50	M33x2	51	4.4	80
0962130050	100	120	50	110	50	63	M42x2	63	7.6	125
0962130063	120	140	63	140	63	71	M48x2	75	17.7	200
0962130080	140	180	80	170	80	90	M64x3	94	30.6	320

For larger sizes, please consult factory.

Rod Eye with Plain Bearing AP4 ISO 8132

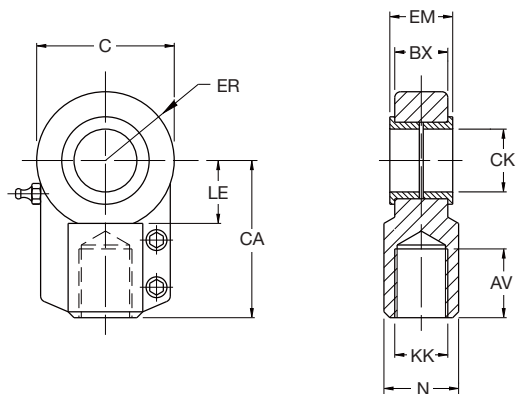

Part No.	AV min	BX max	C max	CA jS13	CK H9	EM h12	ER max	KK	LE min	N max	Mass kg	Nominal Force kN
148731	37	28	70	80	32	32	40	M27x2	30	38	1.2	50
148732	46	34	89	97	40	40	50	M33x2	39	47	2.1	80
148733	57	42	108	120	50	50	63	M42x2	47	58	4.4	125
148734	64	53.5	132	140	63	63	72.5	M48x2	58	70	7.6	200
148735	86	68	168	180	80	80	92	M64x3	74	91	14.5	320
148736 ¹	91	72	185	195	90	90	101	M72x3	85	100	17	400
148737	96	85.5	210	210	100	100	114	M80x3	94	110	28	500
148738 ¹	106	88	235	235	110	110	129	M90x3	105	125	32	635
148739	113	105	262	260	125	125	160	M100x3	116	135	43	800
148740	126	133	326	310	160	160	200	M125x4	145	165	80	1250
148741	161	162	460	390	200	200	250	M160x4	190	215	165	2000

For larger sizes, please consult factory.

Clevis Bracket and Pivot Pin AB4 ISO 8132 Form A

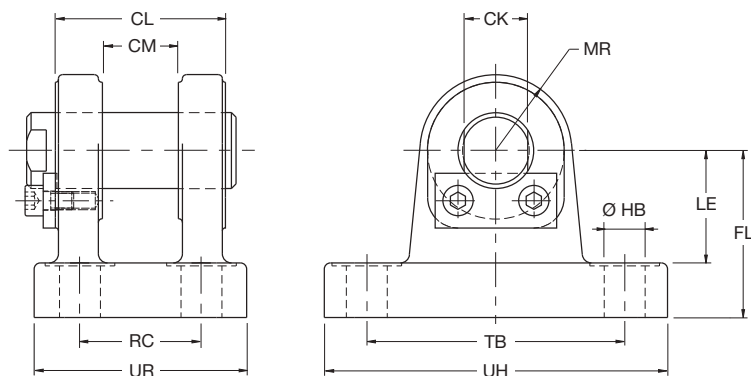

Part No.	CK H9/m6	CL h16	CM A13	FL JS12	HB H13	LE min	MR max	RC JS14	TB JS14	UH max	UR max	Mass kg	Nominal Force kN
0962110032	32	70	32	65	17.5	43	32	50	110	143	85	3.5	50
0962110040	40	90	40	76	22	52	40	65	130	170	108	6	80
0962110050	50	110	50	95	26	65	50	80	170	220	130	12	125
0962110063	63	140	63	112	33	75	63	100	210	270	160	19	200
0962110080	80	170	80	140	39	95	80	125	250	320	210	38	320

¹ Not contained in the standard

For larger sizes, please consult factory.



Rod Eye with Spherical Bearing AP6 ISO 8132

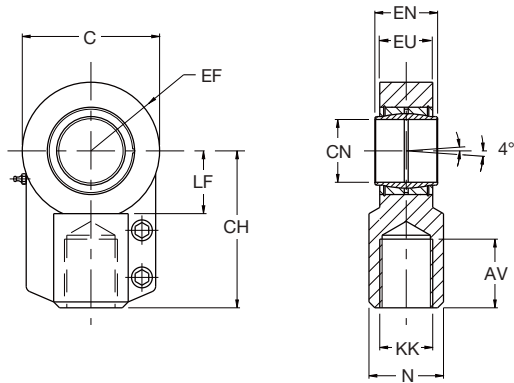

Part No.	AV min	C max	CH js13	CN H7	EF max	EN h12	EU max	KK	LF min	N max	Mass kg	Nominal Force kN
145241	37	72	80	32	40	32	28	M27x2	30	38	1.2	50
145242	46	90	97	40	50	40	34	M33x2	39	47	2.1	80
145243	57	110	120	50	63	50	42	M42x2	47	58	4.4	125
145244	64	136	140	63	72.5	63	53.5	M48x2	58	70	7.6	200
145245	86	170	180	80	92	80	68	M64x3	74	91	14.5	320
148723 ¹	91	185	195	90	101	90	72	M72x3	85	100	17	400
148724	96	212	210	100	114	100	85.5	M80x3	94	110	28	500
148725 ¹	106	235	235	110	129	110	88	M90x3	105	125	32	635
148726	113	265	260	125	160	125	105	M100x3	116	135	43	800
148727	126	326	310	160	200	160	133	M125x4	145	165	80	1250
148728	161	420	390	200	250	200	165	M160x4	190	215	170	2000

Mounting Bracket and Pivot Pin AB3 ISO 8132 Form B

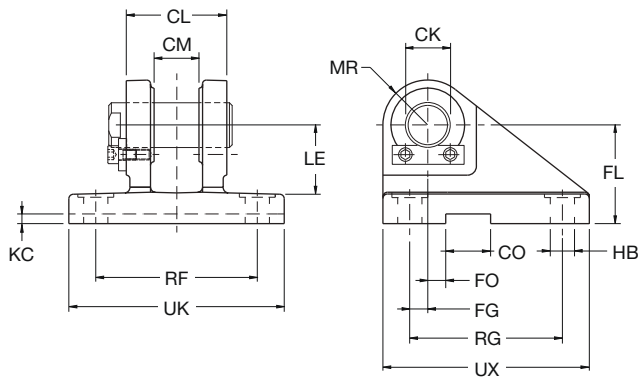

Part No.	CK H9/m6	CL h16	CM A13	CO N9	FG JS14	FL js13	FO JS14	HB H13	KC +0.3	LE min	MR max	RF js13	RG js13	UK max	UX max	Mass kg	Nominal Force kN
0962120032	32	70	32	25	14.5	65	6	17.5	5.4	43	32	110	110	145	145	5	50
0962120040	40	90	40	36	17.5	76	6	22	8.4	52	40	140	125	185	170	9.6	80
0962120050	50	110	50	36	25	95	-	26	8.4	65	50	165	150	215	200	15.5	125
0962120063	63	140	63	50	33	112	-	33	11.4	75	63	210	170	270	230	27.5	200
0962120080	80	170	80	50	45	140	-	39	11.4	95	80	250	210	320	280	47	320

¹ Not contained in the standard

For larger sizes, please consult factory.

Trunnion Block AT4 ISO 8132

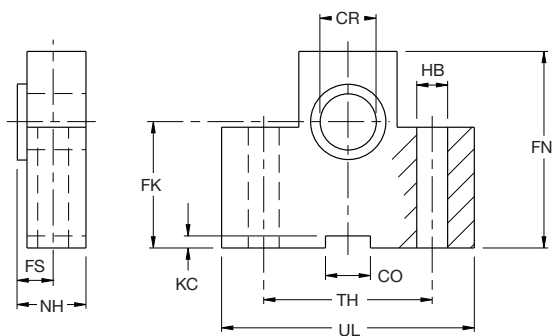

Trunnions

On the 320mm bore cylinder, the trunnion is welded to the cylinder body. On all other bore sizes, the trunnion assembly is threaded to the cylinder body and secured with a locking ring. If a different arrangement is needed to suit a particular application, please consult the factory.

Trunnions require lubricated pillow blocks with minimum bearing clearances. Blocks should be mounted and aligned to eliminate bending moments on the trunnion pins.

Bore Ø	Part No.	CO N9	CR H7	FK JS12	FN max	FS js13	HB H13	KC +0.3	NH max	TH js13	UL max	Mass kg	Nominal Force kN
50	149335	25	32	65	100	15	17.5	5.4	33	110	150	4.7	50
63	149336	36	40	76	120	16	22	8.4	41	125	170	7.8	80
80	149337	36	50	95	140	20	26	8.4	51	160	210	14.3	125
100	149338	50	63	112	180	25	33	11.4	61	200	265	24	200
125	149339	50	80	140	220	31	39	11.4	81	250	325	53	320

For larger sizes, please consult factory.

Cylinder Mounting Information

Mounting Bolts

It is recommended that mounting bolts with a strength to ISO 898/1 grade 12.9 should be used for fixing cylinders to the machine or base. Mounting bolts should be torque loaded to their manufacturer's recommended figures.

Head and Cap Retention Bolts

The head and cap retention bolts on MA3 Series cylinders are torque loaded on assembly in the factory. If damage or corrosion is found on removal, the old bolts must be discarded and replacement bolts with a minimum strength to ISO 898/1 grade 12.9 must be fitted. Head and cap bolts should always be tightened progressively in a diagonal sequence and torque loaded to the figures shown in the table.

Spherical Bearings

All spherical bearings should be re-packed with grease periodically. In unusual or severe working conditions, consult the factory regarding the suitability of the bearing chosen.

Bore Ø	Flange Bolts		
	Torque Load (Nm)	Bolt Size	Bolt Q.ty
50	26-28	M8	8
63	51-54	M10	8
80	112-118	M12	8
100	157-165	M14	8
125	247-260	M16	8
140			
160	518-560	M20	8
180			
200	518-560	M20	12
220	730-769	M22	12
250	850-890	M24	12
320	1460-1540	M33x2	12

Cylinder Masses

Where applicable, accessory masses can be added to give a gross mass.

Bore Ø	Rod No.	SINGLE ROD CYLINDERS					per 10mm Stroke kg
		Mounting Styles at Zero Stroke, in kg					
		MF3 & MF4	MP3 & MP5	MT4	MS2		
50	1	14,8	13,5	14,4	14,9	0,2	
	2	14,8	13,5	14,4	14,9	0,2	
63	1	23	22	22	23	0,3	
	2	23	22	23	23	0,3	
80	1	38	37	39	38	0,5	
	2	38	37	40	38	0,5	
100	1	59	57	61	61	0,5	
	2	60	57	62	61	0,6	
125	1	101	102	112	103	0,7	
	2	101	102	112	103	0,9	
140	1	133	136	154	138	1,0'	
	2	134	136	153	138	1,2	
160	1	193	198	216	201	1,3	
	2	194	199	217	202	1,4	
180	1	255	264	290	265	1,4	
	2	256	265	290	266	1,7	
200	1	317	336	355	324	2,1	
	2	318	337	361	325	2,2	
220	1	488	546	575	505	1,6	
	2	489	548	575	507	2,0'	
250	1	611	659	685	633	3,2	
	2	613	660	688	635	3,6	
320	1	1080	1190	1237	1144	5,0'	
	2	1082	1192	1240	1147	5,6	

DOUBLE ROD CYLINDERS					
Bore Ø	Rod No.	Mounting Styles at Zero Stroke, in kg			per 10mm Stroke kg
		MF3	MT4	MS2	
50	1	17,2	16,6	17,2	0,3
	2	17,5	17,0'	17,6	0,3
63	1	27	26	27	0,4
	2	27	28	27	0,4
80	1	45	44	44	0,6
	2	46	46	45	0,6
100	1	68	70	70	0,9
	2	70	73	71	0,9
125	1	119	130	118	1,2
	2	121	131	119	1,4
140	1	157	176	161	1,6
	2	160	177	161	1,8
160	1	231	252	241	1,9
	2	232	254	243	2,1
180	1	303	335	321	2,2
	2	304	336	323	2,7
200	1	385	429	392	2,8
	2	397	431	400	2,8
220	1	582	662	624	2,9
	2	586	666	628	3,6
250	1	735	798	772	4,8
	2	736	801	776	5,8
320	1	1275	1436	1393	7,6
	2	1280	1438	1401	8,7

Selecting the Cylinder Diameter

Push Force

If the piston rod is in compression, use the Push Force table below.

1. Identify the operating pressure closest to that required.
2. In the same column, identify the force required to move the load (always rounding up).
3. In the same row, look along to the cylinder bore required.

If the cylinder envelope dimensions are too large, increase the operating pressure, if possible, and repeat the exercise.

Bore Ø	Cylinder Bore Area mm ²	Cylinder Push Force in kN				
		50 bar	100 bar	150 bar	200 bar	250 bar
50	1964	10	20	30	40	50
63	3117	15	31	46	63	79
80	5026	25	51	76	102	128
100	7854	40	80	120	160	200
125	12272	62	125	187	250	312
140	15386	77	154	231	308	385
160	20106	102	205	307	410	512
180	25434	127	254	381	508	635
200	31416	160	320	480	640	801
220 ¹	38013	190	380	570	760	950
250	49087	250	500	750	1000	1250
320	80425	410	820	1230	1640	2050

¹ Piston Ø not according with ISO 6022

Pull Force

If the piston rod is in tension, use the Reduction in Cylinder Push Force table below. To determine the pull force:

1. Follow the procedure for Push Force applications, as described.
2. Using the Reduction in Cylinder Push Force table below, establish the force indicated according to the rod diameter and pressure selected.
3. Deduct this from the original push force. The resulting figure is the net force available to move the load.

If this force is not large enough, repeat the process again but increase the system operating pressure or cylinder diameter if possible. If in doubt, please contact our design engineers.

Piston MM Rod Ø	Piston Rod Area mm ²	Reduction in Cylinder Push Force in kN				
		50 bar	100 bar	150 bar	200 bar	250 bar
32	804	4	8	12	16	20
36	1018	5	10	15	20	25
40	1257	6	12	19	24	31
45	1590	8	16	24	32	40
50	1964	10	19	29	38	49
56	2463	12	25	37	50	62
63	3386	17	34	51	68	85
70	3848	19	39	58	78	98
80	5027	25	50	76	100	126
90	6362	32	64	97	129	162
100	7855	39	79	118	158	196
110	9503	48	96	145	193	242
125	12274	61	123	184	246	307
140	15394	78	156	235	313	392
160	20109	100	201	301	402	503
180	25447	129	259	389	518	648
200	31420	157	314	471	628	785
220	38013	198	387	581	775	969

Tolerances according to BS ISO6022

Tolerances on piston stroke

Nominal Stroke	Tolerance ²
≤ 1250	+2 0
> 1250 ≤ 3150	+5 0
> 3150 ≤ 6000	+8 0

² Stroke tolerances must not be added to the tolerances listed in the mounting dimensions

Tolerances for mounting dimensions that are dependent on stroke

Code for mounting dimension	XS ^{3,4}	WF	WC	ZP ³	XC ³	XO ³	XV ³
Type of Mounting	MS2	MF3	MF4	MP3	MP5	MT4	
Nominal Stroke	Tolerances						
≤ 1250	± 2	± 2	± 2	± 1.5	± 1.5	± 1.5	± 2
> 1250 ≤ 3150	± 4	± 4	± 4	± 3	± 3	± 3	± 4
> 3150 ≤ 6000	± 8	± 8	± 8	± 5	± 5	± 5	± 8

³ Length including stroke

⁴ Not standardized

Selecting the Piston Rod

To select a piston rod for thrust (push) conditions:

1. Determine the type of mounting style and rod end connection to be used. From the Stroke Factor Selection table below, identify which factor corresponds to the application.
2. Using this stroke factor, determine the 'basic length' from the equation:

$$\text{Basic Length} = \text{Net Stroke} \times \text{Stroke Factor}$$

(The Piston Rod Selection Chart on page 26 applies to piston rods with standard rod extensions beyond the face of the gland retainer. For rod extensions greater than standard, add the increase to the stroke to arrive at the 'basic length'.)

3. Find the load imposed for the thrust application by multiplying the full bore area of the cylinder by the system pressure, or by referring to the Push and Pull Force tables on page 26.
4. Using the Piston Rod Selection Chart on page 28, look along the values for 'basic length' and 'thrust' as found in 2 and 3 above, and note the point of intersection.

The correct piston rod size is read from the diagonally curved line **above** the point of intersection.

For tensile (pull) loads, the rod size is selected by specifying standard cylinders with standard rod diameters and using them at or below the rated pressure.

Stroke Factor Selection

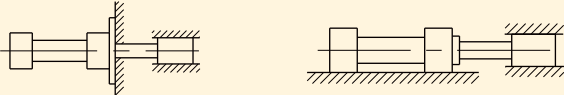
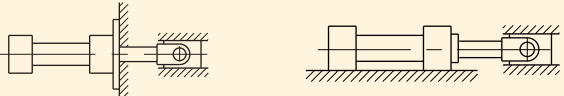
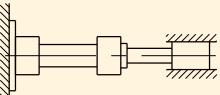
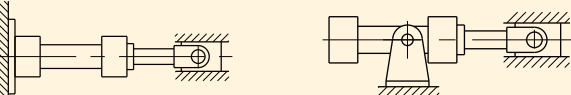
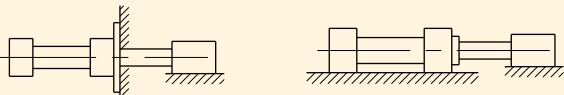
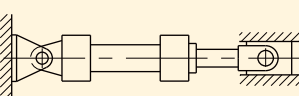
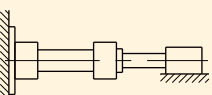
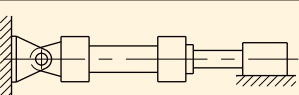
Cylinder Mounting Style	Rod End Connection and Load Guidance	Type of Mounting	Apply Stroke Factor of
MF3 Front flange and MS2 foot mountings	Load is fixed and rigidly guided		0.5
MF3 Front flange and MS2 foot mountings	Load is pivoted and rigidly guided		0.7
MF4 Rear flange mounting	Load is fixed and rigidly guided		1.0
MF4 Rear flange and MT4 trunnion mountings	Load is pivoted and rigidly guided		1.5
MF3 Front flange and MS2 foot mountings	Load is supported but not rigidly guided		2.0
MP3 Rear pivot MP5 mountings	Load is pivoted and rigidly guided		2.0
MF4 Rear flange mounting	Load is supported but not rigidly guided		4.0
MP3 Rear pivot MP5 mountings	Load is supported but not rigidly guided		4.0

Piston Rod Selection Chart

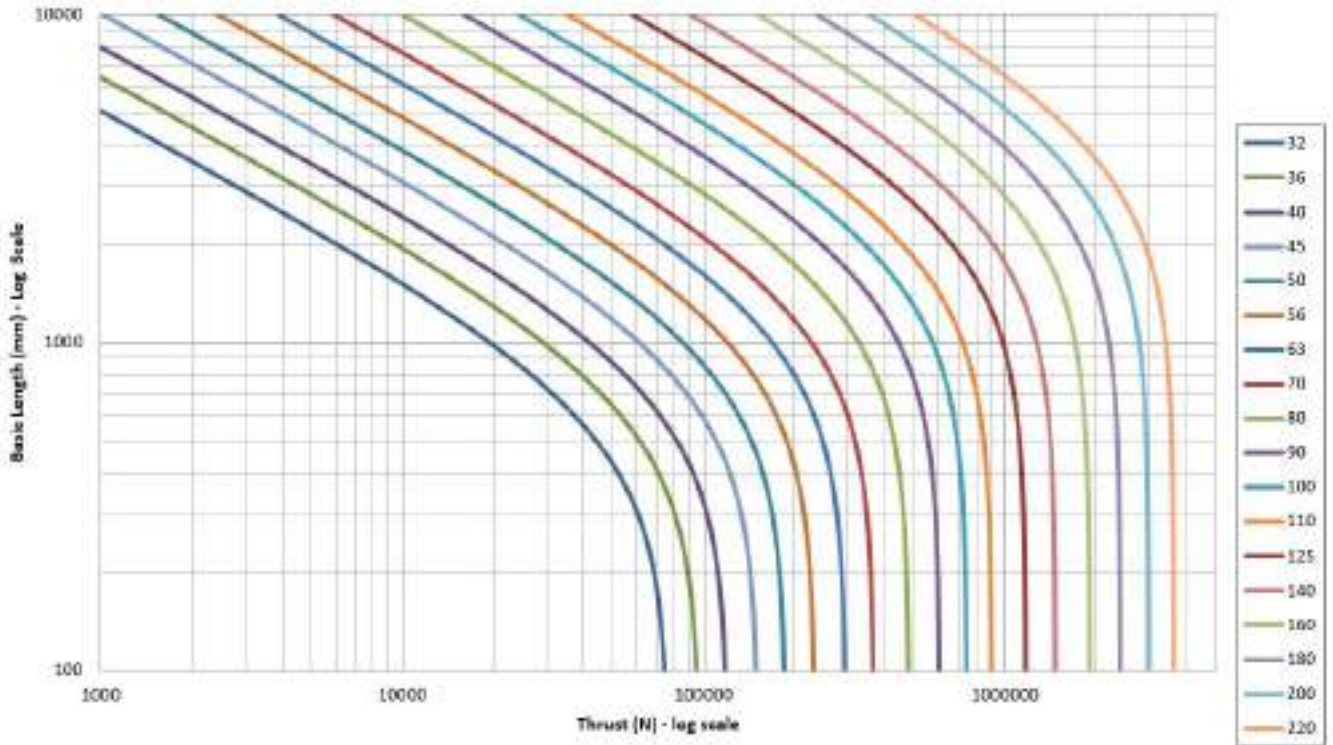

Long Strokes and Stop Tubes

For tension (pull) loads, the rod size is selected by specifying standard cylinders with standard rod diameters, and using them at or below the rated pressure.

For long stroke cylinders under compressive (push) loads, a stop tube should be used to reduce bearing stress. The required length of stop tube is read from the vertical columns on the right of the chart, above, by following the horizontal band within which the point of intersection lies. Note that stop tube requirements differ for fixed and pivot mounted cylinders.

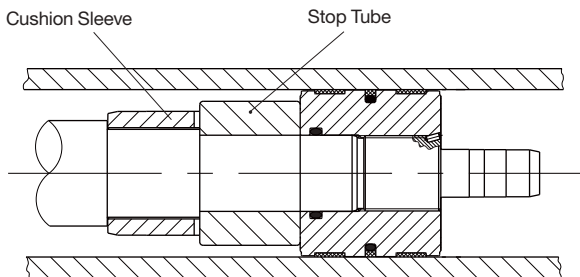

If the required length of stop tube is in the shaded region marked 'consult factory', please submit the following information:

1. Cylinder mounting style.
2. Rod end connection and method of guiding load.
3. Bore and stroke required, and length of rod extension (Dimension W, page 19) if greater than standard.
4. Mounting position of cylinder. If at an angle or vertical, specify the direction of the piston rod.
5. Operating pressure of the cylinder if limited to less than the standard pressure for the cylinder selected.

When specifying a cylinder with a stop tube, please insert an 'S' (Special) and the **net** stroke of the cylinder in the order code, and state the length of the stop tube. Note that net stroke is equal to the gross stroke of the cylinder less the length of the stop tube. The gross stroke determines the envelope dimensions of the cylinder.

Port Size and Piston Speed

Fluid velocity in connecting lines should be limited to 5m/s to minimise fluid turbulence, pressure loss and 'water hammer' effects. The tables below show piston speeds for standard and oversize ports and connecting lines where the velocity of fluid is 5m/s. If the desired piston speed results in a fluid flow in excess of 5m/s in connecting lines, larger lines with two ports per cap should be considered. Parker recommends that a flow rate of 12m/s in connecting lines should not be exceeded.

Bore Ø	Standard Cylinder Port			
	Port Size (BSPP)	Bore of Connecting Lines	Cap End Flow in l/min at 5m/s	Piston Speed m/s
50	G1/2	13	40	0.34
63	G3/4	15	53	0.28
80	G3/4	15	53	0.18
100	G1	19	85	0.19
125	G1	19	85	0.12
140	G1 1/4	22	114	0.13
160	G1 1/4	22	114	0.10
180	G1 1/4	22	114	0.08
200	G1 1/4	22	114	0.07
220	G1 1/2	28	185	0.09
250	G1 1/2	28	185	0.06
320	G1 1/2	28	185	0.04

Bore Ø	Oversize Cylinder Port			
	Port Size (BSPP)	Bore of Connecting Lines	Cap End Flow in l/min at 5m/s	Piston Speed m/s
50	G3/4	15	53	0.45
63	G1	19	85	0.46
80	G1	19	85	0.28
100	G1 1/4	22	114	0.25
125	G1 1/4	22	114	0.16
140	G1 1/2	28	185	0.21
160	G1 1/2	28	185	0.16
180	G1 1/2	28	185	0.13
200	G1 1/2	28	185	0.10
220	G2	38	340	0.15
250	G2	38	340	0.12
320	G2	38	340	0.08

Port Types

In addition to the standard and oversize BSPP ports, metric threaded ports to ISO 9974-1 and ISO 6149, and flange ports to ISO 6162 can also be supplied – see tables below. The ISO 6149 port incorporates a raised ring in the spot face for identification. Other flange port styles are available on request.

Bore Ø	Standard Port			Oversize Port		
	BSPP ISO 1179-1	Metric ISO 9974-1	Metric ISO 6149-1	BSPP ISO 1179-1	Metric ISO 9974-1	Metric ISO 6149-1
50	G1/2	M22x1.5	M22x1.5	G3/4	M27x2	M27x2
63	G3/4	M27x2	M27x2	G1	M33x2	M33x2
80	G3/4	M27x2	M27x2	G1	M33x2	M33x2
100	G1	M33x2	M33x2	G1 1/4	M42x2	M42x2
125	G1	M33x2	M33x2	G1 1/4	M42x2	M42x2
140	G1 1/4	M42x2	M42x2	G1 1/2	M48x2	M48x2
160	G1 1/4	M42x2	M42x2	G1 1/2	M48x2	M48x2
180	G1 1/4	M42x2	M42x2	G1 1/2	M48x2	M48x2
200	G1 1/4	M42x2	M42x2	G1 1/2	M48x2	M48x2
220	G1 1/2	M48x2	M48x2	G2	–	M60x2
250	G1 1/2	M48x2	M48x2	G2	–	M60x2
320	G1 1/2	M48x2	M48x2	G2	–	M60x2

PORTS, AIR BLEEDS AND CUSHION ADJUSTMENT LOCATION

The table below shows standard positions for ports, and cushion adjusting screws where fitted. Many mounting styles can be assembled with ports located at 90° or 180° from standard. In these cases, cushion needle is also repositioned since its relation with the port position does not change. Air bleeds, see page 7, may be fitted in unoccupied sides of the head or cap, depending on mounting. When an air bleed is specified in the standard cushion position, the cushion swill be moved to the alternative position shown in the table.

Positions of Ports and Cushion Screws on head and cap	Mounting Styles			
	MF3, MF4, MP5, MP3			
Port	1	2	3	4
Cushion	2	3	4	1
Alternative cushion	4	4	2	2
MS2				
Port	1	2	3*	4
Cushion	2	4	2	2
Alternative cushion	4	1	4	1
MT4				
Port	1	2	3	4
Cushion	3	3	1	1
Alternative cushion	2	1	2	3

*Please consult the factory.

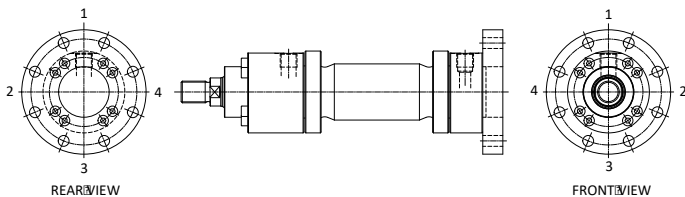

FLANGE PORTS VERSIONS P-A ISO 6162 - 1/2 SAE 3000/SAE 6000

**Rectangular Flange Version 'P'
ISO 6162-1 SAE 3000**

Bore Ø	Size	DN Ø	EB ±0.25	EA ±0.25	ED	T ²	Y	PJ PK	X1	P ¹
50	-	-	-	-	-	-	-	-	-	-
63	1/2"	13	38.1	17.5	M8	16	111	135	55	350
80	1/2"	13	38.1	17.5	M8	16	123.5	148	68	350
100	3/4"	19	47.6	22.3	M10	20	133	173	79	350
125	1"	25	52.4	26.2	M10	20	153	205	98	350
140	1 1/4"	32	58.7	30.2	M10	20	162	227	107	250
160	1 1/4"	32	58.7	30.2	M10	20	181.5	242	127	250
180	1 1/2"	38	69.9	35.7	M12	24	193	266	139	200
200	1 1/2"	38	69.9	35.7	M12	24	219	280	146.5	200

Port dimensions of bore Ø 125 ÷ Ø 200 not standardized

¹ Maximum working pressure MPa (bar)

² Thread depth

³ Max pressure referred to flange not at cylinder

**Rectangular Flange Version 'A'
ISO 6162-2 SAE 6000**

Bore Ø	Size	DN Ø	EB ±0.25	EA ±0.25	ED	T ²	Y	PJ PK	X1	P ³
50	-	-	-	-	-	-	-	-	-	-
63	-	-	-	-	-	-	-	-	-	-
80	1/2"	13	40.5	18.2	M8	16	120	155	67	400
100	1/2"	13	40.5	18.2	M8	16	134	171	80.5	400
125	3/4"	19	50.8	23.8	M10	20	153	205	97	400
140	1"	25	57.2	27.8	M12	24	162	227	107	400
160	1"	25	57.2	27.8	M12	24	181.5	242	127	400
180	1 1/4"	32	66.6	31.8	M14	26	194	264	139.5	400
200	1 1/4"	32	66.6	31.8	M14	26	220	278	147	400
220	1 1/2"	38	79.3	36.5	M16	30	244	326	168	400
250	1 1/2"	38	79.3	36.5	M16	30	257	326	189	400
320	2	51	96.8	44.5	M20	36	282	391	236	400

Version not standardized

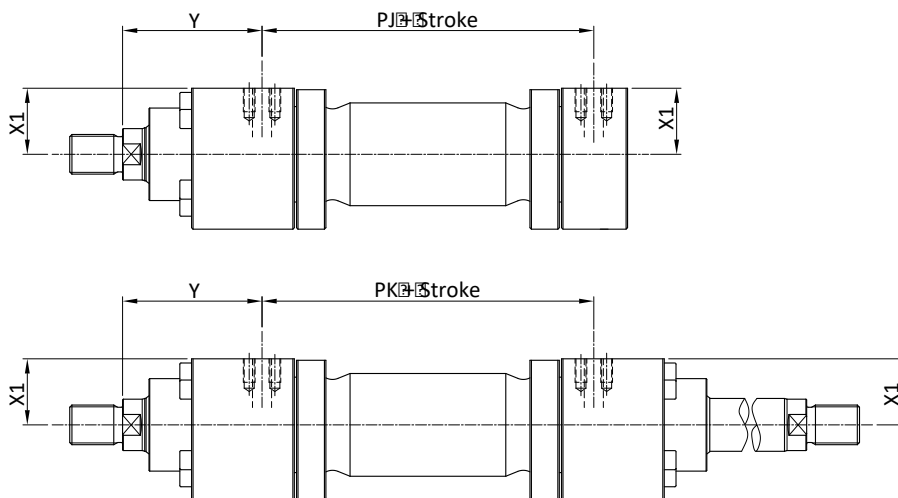
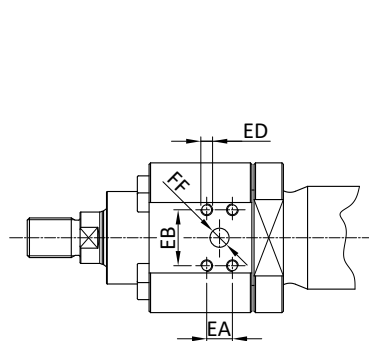

FLANGE PORTS VERSIONS C-D ISO 6164

Square Flange Version 'C'
ISO 6164 (250 bar)

Bore Ø	DN Ø	EA ±0.25	ED	T ²	Y	PJ PK	X1	P ¹
50	10	24.7	M6	14	97	122	48	250
63	13	29.7	M8	16	111	135	57	250
80	13	29.7	M8	16	123.5	148	69.5	250
100	19	35.4	M8	16	133	173	81.5	250
125	19	35.4	M8	16	57	197	100	250
140	25	43.8	M10	20	162	227	109	250
160	25	43.8	M10	20	181.5	242	128.5	250
180	32	51.6	M12	24	194	264	142	250
200	32	51.6	M12	24	220	278	148.5	250

Port dimensions of bore Ø 50-180-200 not standardized

¹ Maximum working pressure MPa (bar)

² Thread depth

³ Max pressure referred to flange not at cylinder

Square Flange Version 'D'
ISO 6164 (400 bar)

Bore Ø	DNØ	EA ±0.25	ED	T ²	Y	PJ PK	X1	P ³
50	10	24.7	M6	14	97	122	48	400
63	13	29.7	M8	16	111	135	57	400
80	13	29.7	M8	16	123.5	148	69.5	400
100	19	35.4	M8	16	133	173	81.5	400
125	19	35.4	M8	16	157	197	100	400
140	25	43.8	M10	20	162	227	109	400
160	25	43.8	M10	20	181.5	242	128.5	400
180	32	51.6	M12	24	194	264	142	400
200	32	51.6	M12	24	220	278	148.5	400
220	38	60.1	M16	30	244	326	171	400
250	38	60.1	M16	30	257	326	192	400
320	51	69.3	M16	30	282	391	240	400

Version not standardized

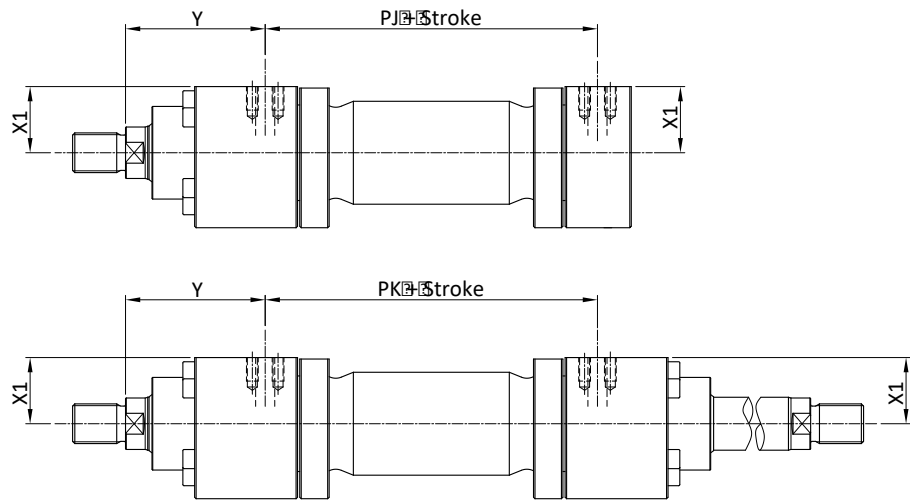
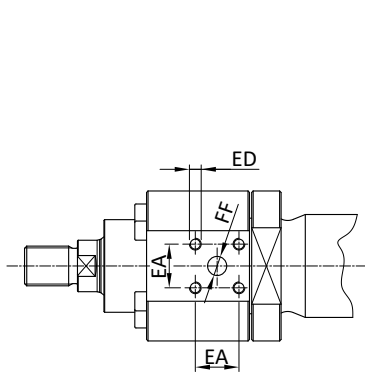

Seals and Fluid Data

See also Gland and Piston Seal Options

Fluid Group	Seal Materials – a combination of:	Fluid Medium to ISO 6743/4-1982	Piston & Gland Type	Temperature Range
1	Nitrile (NBR), PTFE, enhanced polyurethane (AU)	Mineral Oil HH, HL, HLP, HLP-D, HM, HV, MIL-H-5606 oil, air, nitrogen	All	-20°C to +80°C
2	Nitrile (NBR), PTFE	Water glycol (HFC)	Chevron and Low Friction	-20°C to +60°C
5	Fluorocarbon elastomer (FPM), PTFE	Fire resistant fluids based on phosphate esters (HFD-R). Also suitable for hydraulic oil at high temperatures or in hot environments. Not suitable for use with Skydrol. See fluid manufacturer's recommendations.	Chevron and Low Friction	-20°C to +150°C
6	Various compounds including nitrile, enhanced polyurethane, fluorocarbon elastomers and PTFE	Water Oil in water emulsion 95/5 (HFA)	Chevron and Low Friction	+5°C to +55°C
7		Water in oil emulsion 60/40 (HFB)		

Special Seals

A range of seal options is available for the fluid groups listed above – see How to Order on page 38. Where required, special seals, in addition to those listed above, can also be supplied. Please insert an S (Special) in the model number and specify the fluid medium when ordering.

Group 6 Seal Life

Seal life is reduced with High Water Content Fluids (HFA) due to the poor lubricity of the operating medium. Note that seal life also declines as pressure increases.

Water Service

Special modifications are available for high water content fluids. These include a stainless steel piston rod, and plating of internal surfaces. When ordering, please specify the maximum operating pressure or load/speed conditions, as the stainless steel rod is of lower tensile strength than the standard material.

Filtration

Fluid cleanliness should be in accordance with ISO 4406. The quality of filters should be in accordance with the appropriate ISO standards.

The rating of the filter media depends on the system components and the application. The minimum required should be class 19/15 to ISO 4406, which equates to 25µ (β10≥75) to ISO 4572.

Warranty

Parker Hannifin warrants cylinders modified for water or high water content fluid service to be free of defects in materials or workmanship, but cannot accept responsibility for premature failure caused by excessive wear resulting from lack of lubricity, or where failure is caused by corrosion, electrolysis or mineral deposits within the cylinder.

Repairs

Although MA3 cylinders are designed to make on site maintenance or repairs as easy as possible, some operations should only be carried out in our factory. It is standard policy to fit a cylinder returned to the factory for repair with those replacement parts which are necessary to return it to 'as good as new' condition. Should the condition of the returned cylinder be such that the expense would exceed the cost of a new one, you will be notified.

An Introduction to Cushioning

Cushioning is recommended as a means of controlling the deceleration of masses, or for applications where piston speeds are in excess of 0.1m/s and the piston will make a full stroke. Cushioning extends cylinder life and reduces undesirable noise and hydraulic shock.

Built-in deceleration devices or 'cushions' are optional and can be supplied at the head and cap ends of the cylinder without affecting its envelope or mounting dimensions. Cushions are adjustable via recessed needle valves.

Standard Cushioning

Ideal cushion performance shows an almost uniform absorption of energy along the cushion's length. Where specified, MA3 cylinders use specially profiled cushions, giving a performance which comes close to the ideal in the majority of applications. The head and cap cushion performance for each bore size is illustrated on the charts on page 35.

Alternative Forms of Cushioning

Special designs can be produced to suit applications where the energy to be absorbed exceeds the performance of the standard cushion. Please consult the factory for details.

Cushion Length

All MA3 cylinder cushions incorporate the longest cushion sleeve and spear that can be provided in the standard envelope without decreasing the rod bearing and piston bearing lengths – see table of cushion lengths on page 33.

Cushion Calculations

The charts on page 35 show the energy absorption capacity for each bore and rod combination at the head (annulus) and the cap (full bore) ends of the cylinder. The charts are valid for piston velocities in the range of 0.1–0.3m/s. For velocities between 0.3m/s–0.5m/s, the energy values from the charts should be reduced by 25%. For velocities of less than 0.1m/s where large masses are involved, and for velocities greater than 0.5m/s, a special cushion profile may be required. Please consult the factory.

The cushion capacity of the head end is less than that of the cap, owing to the pressure intensification effect across the piston.

The energy absorption capacity of the cushion decreases with drive pressure, which in normal circuits is the relief valve setting.

Formulae

Cushioning calculations are based on the formula: $E = \frac{1}{2}mv^2$ for horizontal applications. For inclined or vertically downward or upward applications, this is modified to:

$E = \frac{1}{2}mv^2 + mgl \times 10^{-3} \times \sin\alpha$
– for inclined or vertically downward direction of mass;

$E = \frac{1}{2}mv^2 - mgl \times 10^{-3} \times \sin\alpha$
– for inclined or vertically upward direction of mass.

Where:

- E = energy absorbed in Joules
- g = acceleration due to gravity = 9.81m/s²
- v = velocity in metres/second
- l = length of cushion in millimetres (see page 33)
- m = mass of load in kilogrammes (including piston and rod, see page 33, and rod end accessories, pages 16,17,18,19)
- α = angle to horizontal in degrees
- ρ = pressure in bar

Example

The following example shows how to calculate the energy developed by masses moving in a straight line. For non-linear motion, other calculations are required; please consult the factory. The example assumes that the bore and rod diameters are already appropriate for the application. The effects of friction on the cylinder and load have been ignored.

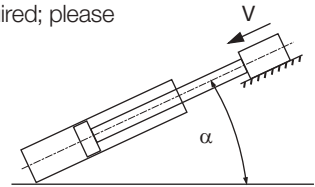

- Selected bore/rod = 80/50mm (no. 1 rod)
- Cushioning at the cap end
- Pressure = 150 bar
- Mass = 7710 kg
- Velocity = 0.4m/s
- α = 45°
- Sin α = 0.7
- Cushion length = 45mm

$E = \frac{1}{2}mv^2 + mgl \times 10^{-3} \times \sin\alpha$
 $E = \frac{7710 \times 0.4^2}{2} + 7710 \times 9.81 \times \frac{45}{10^3} \times 0.7$
 $E = 617 + 2383 = 3000 \text{ Joules}$

Note: as velocity is greater than 0.3m/s, the energy absorption figures obtained from the charts on page 33 should be reduced by 25% – see Cushion Calculations, above. Comparison with the cushioning chart curve for this cylinder shows an energy capacity for the cap end cushion of 5100 Joules. Reducing this by 25% gives a capacity of 3825 Joules, so the standard cushion can safely decelerate the 3000 Joules in this example.

Where cushion performance figures are critical, our engineers can run a computer simulation to determine accurate cushion performance – please contact the factory for details.

Cushion Energy Absorption Data

The cushion energy absorption capacity data shown below are based on the maximum fatigue-free pressures developed in the cylinder tube. If working life cycle applications of less than 10⁶ cycles are envisaged, then greater energy absorption figures can be applied. Please consult the factory if further information is required.

Cushion Length, Piston & Rod Mass

Bore Ø	Rod No.	MM Rod Ø	Cushion Length	Piston & Rod Zero stroke kg	Rod per 10mm Stroke kg
50	1	32	30	2.0	0.06
	2	36		2.3	0.08
63	1	40	40	3.4	0.10
	2	45		4.0	0.12
80	1	50	45	5.8	0.15
	2	56		6.7	0.19
100	1	63	55	10.7	0.24
	2	70		12.1	0.30
125	1	80	60	20.7	0.39
	2	90		23.8	0.50
140	1	90	60	28.0	0.50
	2	100		31.0	0.62
160	1	100	65	40.1	0.62
	2	110		44.6	0.75
180	1	110	65	54.0	0.75
	2	125		62.0	0.96
200	1	125	65	76.2	0.96
	2	140		86.0	1.21
220 ¹	1	140	65	107.4	1.21
	2	160		118.7	1.58
250	1	160	90	131.8	1.58
	2	180		150.2	2.00
320	1	200	100	250.2	2.46
	2	220		279.7	2.98

¹ Piston Ø not according with ISO 6022
All dimensions are in millimetres unless otherwise stated.

Head End, No. 1 Rod and No. 2 Rods

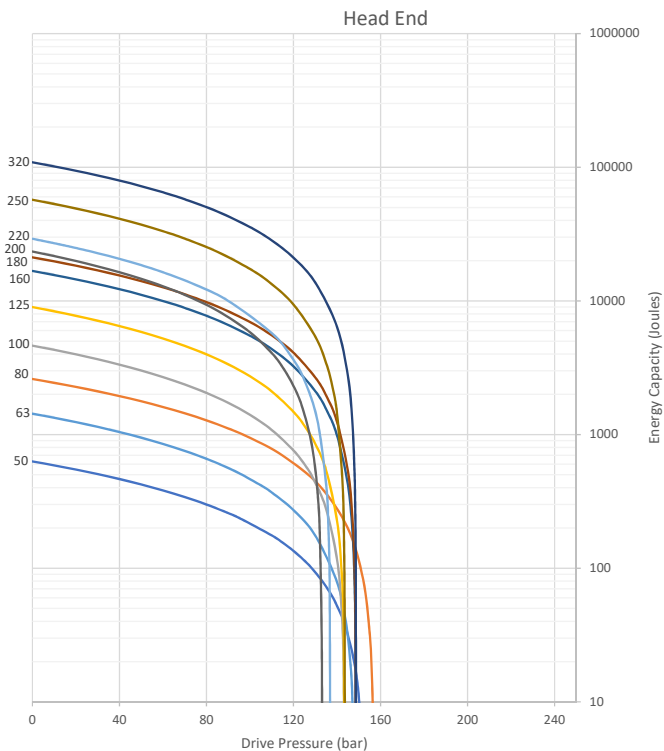

Cap End, No. 1 and No. 2 Rods

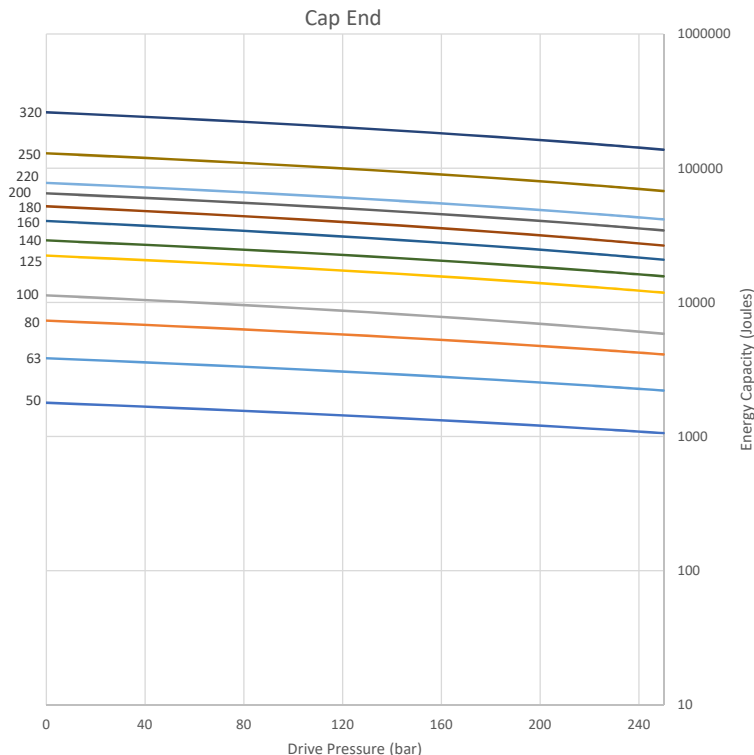

Service Kits

When ordering service kits, please refer to the identification plate on the cylinder body, and supply the following information:

Serial Number - Bore - Stroke - Model Number - Fluid Type

Key to Part Numbers

- 1 Head
- 7 Cap
- 14a Standard and Low Friction gland
- 14b Chevron gland
- 15 Cylinder tube
- 17 Piston
- 17a Chevron piston – head end
- 17b Chevron piston – cap end
- 18 Cushion sleeve
- 19 Front/rear flange
- 23 Head/cap securing screw
- 26 O-ring (cylinder body)

- 132 Energising ring for Low Friction piston seal
- 133 Wear ring for Low Friction piston
- 134 O-ring back up washer (gland/head)
- 136 Gland securing screw
- 137 Chevron rod seal assembly
- 138 Back up washer – Chevron rod seal assembly
- 139a Wear ring for Chevron gland
- 139b Wear rings for Chevron gland
- 140a Wear ring for Standard gland
- 140b Wear rings for Standard gland
- 141a Wear ring for Low Friction gland
- 141b Wear rings for Low Friction gland
- 142 Chevron piston bearing ring
- 143 Chevron piston seal assembly

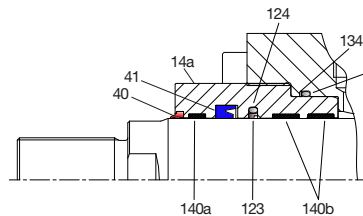
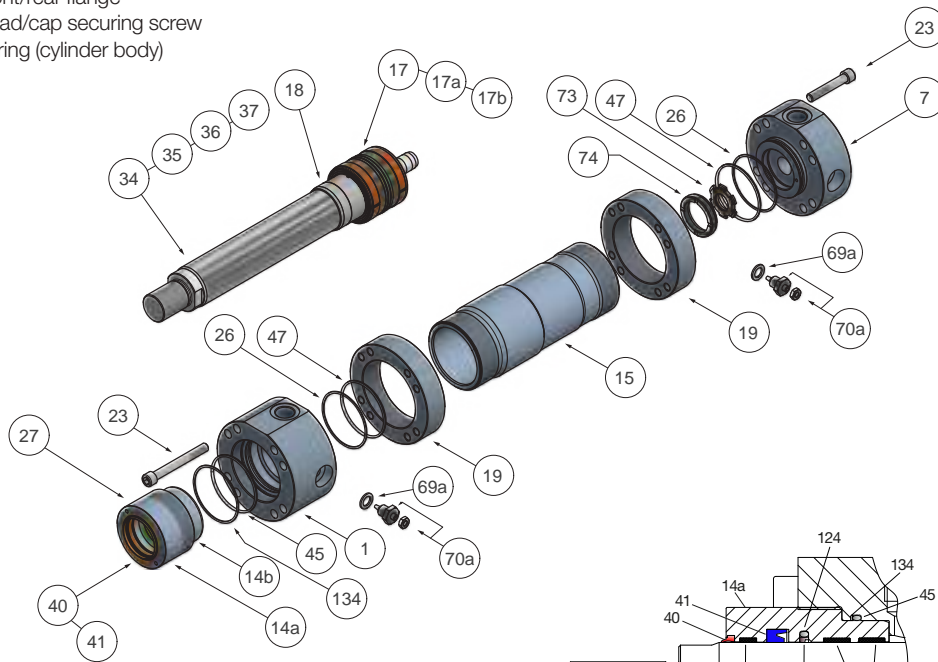

Standard Gland & Seals

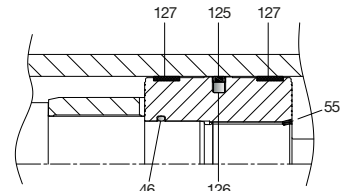

Standard Piston

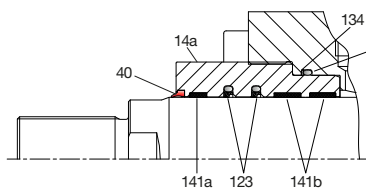

Low Friction Gland & Seals

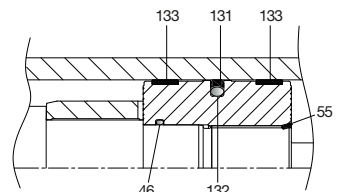

Low Friction Piston

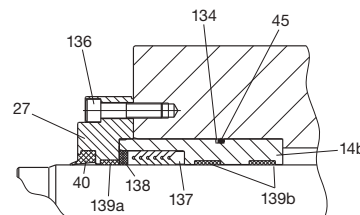

Chevron Gland & Seals

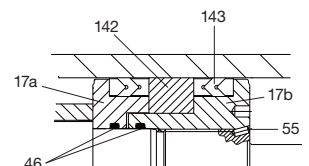

Chevron Piston

- 27 Gland retainer (secured by screws or threaded)
- 34 Piston rod – single rod, no cushion
- 35 Piston rod – single rod, cushion at head end
- 36 Piston rod – single rod, cushion at cap end
- 37 Piston rod – single rod, cushion at both ends
- 40 Gland wiperseal
- 41 Lipseal
- 45 O-ring (gland/head)
- 46 O-ring, piston/rod (2 off – Chevron piston)
- 47 Back-up washer for cylinder body O-ring 26
- 55 Piston locking pin
- 69a Cushion needle valve cartridge sealing washer
- 70a Cushion needle valve cartridge
- 73 Floating cushion bush
- 74 Cushion bush retaining ring
- 123 Stepseal
- 124 Pre-load ring for stepseal 123
- 125 Standard piston seal
- 126 Energising ring for Standard seal 125
- 127 Wear ring for Standard piston
- 131 Low Friction piston seal

Contents and Part Numbers of Service Kits

See key to part numbers on page 38.

Gland Service Cartridge Kit, Standard and Loadholding Seals Contains items 14a, 40, 41, 45, 123, 124, 134, 140a, and two of 140b.

Gland Service Cartridge Kit, Chevron Seals Contains items 14b, 40, 45, 134, 137, 138, 139a, and two of 139b.

Gland Service Cartridge Kit, Low Friction Seals Contains items 14a, 40, 45, 134, 141a, and two each of 123, 124, 141b.

Gland Service Kit, Standard and Loadholding Seals Contains items 40, 41, 45, 123, 124, 134, 140a, and two of 140b.

Gland Service Kit, Chevron Seals Contains items 40, 45, 134, 137, 138, 139a, and two of 139b.

Gland Service Kit, Low Friction Seals Contains items 40, 45, 134, 141a, and two each of 123, 124, 141b.

Piston Service Kit, Standard Seals Contains items 46, 125, 126, and two of 26, 47 and 127.

Piston Service Kit, Chevron and Loadholding Seals Contains items 142, and two each of 26, 46, 47 and 143.

Piston Service Kit, Low Friction Seals Contains items 46, 131, 132, and two of 26, 47 and 133.

Optional Seal Groups – Ordering

The order codes listed for Chevron and Low Friction service kits contain standard, Group 1 seals. To order kits with other classes of seals, see page 28, replace the last digit of the part number shown with the number of the service group required. Eg: RGF210MA30701, containing a Group 1 seal, becomes RGF210MA30705 when it contains a Group 5 seal.

Service Kit Order Codes – Piston

Bore Ø	Piston Service Kit		
	Standard Seals *	Chevron & Loadholding Seals	Low Friction Seals
50	PN050MA301	PL050MA301	PF050MA301
63	PN063MA301	PL063MA301	PF063MA301
80	PN080MA301	PL080MA301	PF080MA301
100	PN100MA301	PL100MA301	PF100MA301
125	PN125MA301	PL125MA301	PF125MA301
140	PN140MA301	PL140MA301	PF140MA301
160	PN160MA301	PL160MA301	PF160MA301
180	PN180MA301	PL180MA301	PF180MA301
200	PN200MA301	PL200MA301	PF200MA301
220	PN220MA301	PL220MA301	PF220MA301
250	PN250MA301	PL250MA301	PF250MA301
320	PN320MA301	PL320MA301	PF320MA301

Service Kit Order Codes – Glands

Bore Ø	Rod No.	MM Rod Ø	Gland Service Cartridge Kit			Gland Service Kit		
			Standard & Loadholding Seals*	Chevron Seals	Low Friction Seals	Standard & Loadholding Seals*	Chevron Seals	Low Friction Seals
50	1	32	RGN05MA30321	RGL05MA30321	RGF05MA30321	RKN05MA30321	RKL05MA30321	RKF05MA30321
	2	36	RGN05MA30361	RGL05MA30361	RGF05MA30361	RKN05MA30361	RKL05MA30361	RKF05MA30361
63	1	40	RGN06MA30401	RGL06MA30401	RGF06MA30401	RKN06MA30401	RKL06MA30401	RKF06MA30401
	2	45	RGN06MA30451	RGL06MA30451	RGF06MA30451	RKN06MA30451	RKL06MA30451	RKF06MA30451
80	1	50	RGN08MA30501	RGL08MA30501	RGF08MA30501	RKN08MA30501	RKL08MA30501	RKF08MA30501
	2	56	RGN08MA30561	RGL08MA30561	RGF08MA30561	RKN08MA30561	RKL08MA30561	RKF08MA30561
100	1	63	RGN10MA30631	RGL10MA30631	RGF10MA30631	RKN10MA30631	RKL10MA30631	RKF10MA30631
	2	70	RGN10MA30701	RGL10MA30701	RGF10MA30701	RKN10MA30701	RKL10MA30701	RKF10MA30701
125	1	80	RGN12MA30801	RGL12MA30801	RGF12MA30801	RKN12MA30801	RKL12MA30801	RKF12MA30801
	2	90	RGN12MA30901	RGL12MA30901	RGF12MA30901	RKN12MA30901	RKL12MA30901	RKF12MA30901
140	1	90	RGN14MA30901	RGL14MA30901	RGF14MA30901	RKN14MA30901	RKL14MA30901	RKF14MA30901
	2	100	RGN14MA31001	RGL14MA31001	RGF14MA31001	RKN14MA31001	RKL14MA31001	RKF14MA31001
160	1	100	RGN16MA31001	RGL16MA31001	RGF16MA31001	RKN16MA31001	RKL16MA31001	RKF16MA31001
	2	110	RGN16MA31101	RGL16MA31101	RGF16MA31101	RKN16MA31101	RKL16MA31101	RKF16MA31101
180	1	110	RGN18MA31101	RGL18MA31101	RGF18MA31101	RKN18MA31101	RKL18MA31101	RKF18MA31101
	2	125	RGN18MA31251	RGL18MA31251	RGF18MA31251	RKN18MA31251	RKL18MA31251	RKF18MA31251
200	1	125	RGN20MA31251	RGL20MA31251	RGF20MA31251	RKN20MA31251	RKL20MA31251	RKF20MA31251
	2	140	RGN20MA31401	RGL20MA31401	RGF20MA31401	RKN20MA31401	RKL20MA31401	RKF20MA31401
220	1	140	RGN22MA31401	RGL22MA31401	RGF22MA31401	RKN22MA31401	RKL22MA31401	RKF22MA31401
	2	160	RGN22MA31601	RGL22MA31601	RGF22MA31601	RKN22MA31601	RKL22MA31601	RKF22MA31601
250	1	160	RGN25MA31601	RGL25MA31601	RGF25MA31601	RKN25MA31601	RKL25MA31601	RKF25MA31601
	2	180	RGN25MA31801	RGL25MA31801	RGF25MA31801	RKN25MA31801	RKL25MA31801	RKF25MA31801
320	1	200	RGN32MA32001	RGL32MA32001	RGF32MA32001	RKN32MA32001	RKL32MA32001	RKF32MA32001
	2	220	RGN32MA32201	RGL32MA32201	RGF32MA32201	RKN32MA32201	RKL32MA32201	RKF32MA32201

* only available with group 1 seals

How To Order

Code-Key

80	C	K	MF3	MA3	R	N	S	1	4	M	C	300	M	11	00
1	2	3	4	5	6	7	8	9	10	11	12	13	14	15	16

1	Bore	50, 63, 80, 100, 125, 140, 160, 180, 200, 220, 250, 320	
2	Cushion Head	C	① p.35
3	Double Rod	K	① p.13,15, 17
4	Mounting Style	MF3 (Head Circular Flange), MF4 (Cap Circular Flange), MP3 (Cap Fixed Eye), MP5 (Cap Fixed Eye with Spherical Bearing), MT4 (Intermediate Trunnion), MS2 (Foot Mounting)	① p.12 ① p.11 ① p.19 ① p.18 ① p.15, 16 ① p.14
5	Series	MA3	
6	Port Style	R (BSP Parallel ISO 1179-1), M (Metric to ISO 9974-1), Y (Metric to ISO 6149), P (Flange Ports to ISO 6162-1), A (Flange Ports to ISO 6162-2), C (Flange Ports to ISO 6164 Table 1), D (Flange Ports to ISO 6164 Table 2)	① p.30 ① p.30 ① p.30 ① p.30 ① p.30 ① p.30 ① p.30
7	Gland and Piston Type	N (Standard, Group 1 Fluids only), F (Low Friction), L (Chevron), A (Load Holding, Group 1 Fluids only), E (Special Design)	① p.09 ① p.09 ① p.09 ① p.09
8	Special Features	S Oversized Ports S Special Position for Cushion or Air Bleeds S Special Seals S Stop Tube (or customer specification) S Rod Belows S Drain S Proximity Switches S Test point (minimess)	① p.30 ① p.30 ① p.33 ① p.28 ① p.20 ① p.09 ① p.09 ① p.20
9	Piston Rod Number	1 (Rod No. 1), 2 (Rod No. 2)	① p.21 ① p.21
10	Piston Rod End	4 (Code 4), 9 (Code 9), 3 (Code 3 - Special, description or drawing needed)	① p.21 ① p.21 ① p.20
11	Rod Thread	M (Metric - Standard)	① p.21
12	Cushion Cap	C	
13	Net Stroke	300	
14	Fluid Medium	M (Group 1), C (Group 2), D (Group 5), A1 (Group 6), B (Group 7)	① p.33 ① p.33 ① p.33 ① p.33 ① p.33
15	Port Positions	11 (Head and Cap Position 1-4)	① p.30
16	Air Bleeds	44 (Head and Cap Position 1-4), 00 (No Air Bleeds)	① p.30 ① p.30

Key

Indicate optional features or leave blank

Accessories

Please state on order whether accessories are to be assembled to cylinder or supplied separately.

Port Positions and Air Bleeds

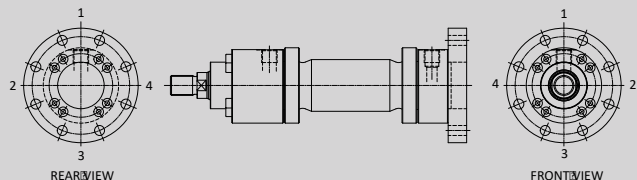

Easy customising and ordering with Parker's eConfigurator

Using our eConfigurator on parker.com when customising and ordering your required MA3 cylinder, holds many benefits.



- ⇒ Select requested attributes
- ⇒ Immediate access to needed support assets, such as CAD files and manuals
- ⇒ Improved quoting and service process

In the event that you have additional questions or concerns, or if more information is required, please contact your local Parker distributor or our customer service representative for assistance.

Parker Worldwide

Europe, Middle East, Africa

AE – United Arab Emirates,

Dubai

Tel: +971 4 8127100

AT – Austria, St. Florian

Tel: +43 (0)7224 66201

AZ – Azerbaijan, Baku

Tel: +994 50 2233 458

BE/NL/LU – Benelux,

Hendrik Ido Ambacht

Tel: +31 (0)541 585 000

BY – Belarus, Minsk

Tel: +48 (0)22 573 24 00

CH – Switzerland, Etoy

Tel: +41 (0)21 821 87 00

CZ – Czech Republic,

Prague

Tel: +420 284 083 111

DE – Germany, Kaarst

Tel: +49 (0)2131 4016 0

DK – Denmark, Ballerup

Tel: +45 43 56 04 00

ES – Spain, Madrid

Tel: +34 902 330 001

FI – Finland, Vantaa

Tel: +358 (0)20 753 2500

FR – France, Contamine s/Arve

Tel: +33 (0)4 50 25 80 25

GR – Greece

Tel: +30 69 44 52 78 25

HU – Hungary, Budaörs

Tel: +36 23 885 470

IE – Ireland, Dublin

Tel: +353 (0)1 466 6370

IL – Israel

Tel: +39 02 45 19 21

IT – Italy, Corsico (MI)

Tel: +39 02 45 19 21

KZ – Kazakhstan, Almaty

Tel: +7 7273 561 000

NO – Norway, Asker

Tel: +47 66 75 34 00

PL – Poland, Warsaw

Tel: +48 (0)22 573 24 00

PT – Portugal

Tel: +351 22 999 7360

RO – Romania, Bucharest

Tel: +40 21 252 1382

RU – Russia, Moscow

Tel: +7 495 645-2156

SE – Sweden, Borås

Tel: +46 (0)8 59 79 50 00

SL – Slovenia, Novo Mesto

Tel: +386 7 337 6650

TR – Turkey, Istanbul

Tel: +90 216 4997081

UK – United Kingdom, Warwick

Tel: +44 (0)1926 317 878

ZA – South Africa, Kempton Park

Tel: +27 (0)11 961 0700

North America

CA – Canada, Milton, Ontario

Tel: +1 905 693 3000

US – USA, Cleveland

Tel: +1 216 896 3000

Asia Pacific

AU – Australia, Castle Hill

Tel: +61 (0)2-9634 7777

CN – China, Shanghai

Tel: +86 21 2899 5000

HK – Hong Kong

Tel: +852 2428 8008

IN – India, Mumbai

Tel: +91 22 6513 7081-85

JP – Japan, Tokyo

Tel: +81 (0)3 6408 3901

KR – South Korea, Seoul

Tel: +82 2 559 0400

MY – Malaysia, Shah Alam

Tel: +60 3 7849 0800

NZ – New Zealand, Mt Wellington

Tel: +64 9 574 1744

SG – Singapore

Tel: +65 6887 6300

TH – Thailand, Bangkok

Tel: +662 186 7000

TW – Taiwan, Taipei

Tel: +886 2 2298 8987

South America

AR – Argentina, Buenos Aires

Tel: +54 3327 44 4129

BR – Brazil, Sao Jose dos Campos

Tel: +55 080 0727 5374

CL – Chile, Santiago

Tel: +56 22 303 9640

MX – Mexico, Toluca

Tel: +52 72 2275 4200

European Product Information Centre

Free phone: 00 800 27 27 5374

(from AT, BE, CH, CZ, DE, DK, EE, ES, FI, FR, IE, IL, IS, IT, LU, MT, NL, NO, PL, PT, RU, SE, SK, UK, ZA)

Parker Hannifin Ltd.

Tachbrook Park Drive

Tachbrook Park,

Warwick, CV34 6TU

United Kingdom

Tel.: +44 (0) 1926 317 878

www.parker.com

